

Fraunhofer

Institut
Fabrikbetrieb
und -automatisierung

Achievements and Results 2007 Annual Report

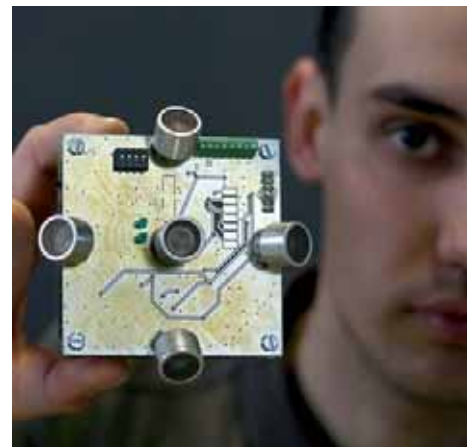
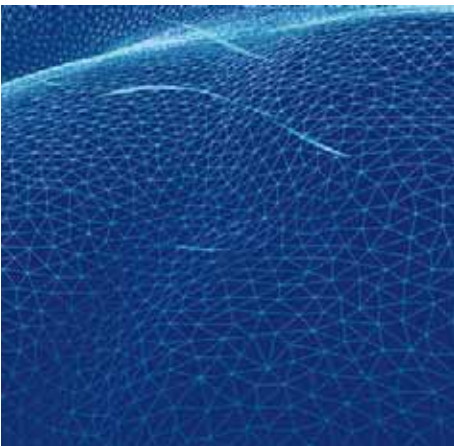

Achievements and
Results
2007 Annual Report

Contents

Introduction		Project Reports from the Robotic Systems Business Unit	World Class Launch 2020: Around the World in Sixty-six Days - A Paradigm Change in the Automotive Industry		
Foreward	6	New Fields of Application for Industrial Robots: Casting Models and Molds for Prototyping	18	40	
Greeting Developing "Rapid Logistics" with the Aid of Research	8	Interactive Human and Machine: Service Robot LISA Cooperates with Humans in Labs	20	Interregional Collaboration on Biomass Utilization	42
The Institute		A Virtual Environment to Overcome Interdisciplinary Barriers to the Use of Lab Robots	22	Condition Monitoring of Components of Wind Energy Converter Drive Trains	44
Mission	10	Project Reports from the Measurement and Testing Technology Business Unit		Transferring European Best Practices to Promote Sustainable Management in Thai and Vietnamese Enterprises	46
The Institute in Figures	11	Engineering and Commissioning of Optical Dimensional Inspection Systems for 3-D Manufacturing Metrology	26	Project Reports from the Material Handling Engineering and Systems Expert Group	
Advisory Board	12	3-D Visualization of Readings in Optical Manufacturing Metrology OptoInspect3D®	28	Innovative Technologies and Their Demonstration for Localization in Buildings	50
Career Start at the Fraunhofer IFF: European Training Program for Young Researchers	14	Moisture Detection System for Emission Measurements	30	Radio-based Interaction Analysis to Evaluate Pedestrian Flows	52
		Automatic Laser Heat-sealing of Large Film Elements	32	Cleverly through Downtown with Interchangeable Trailers	54
		Project Reports from the Logistics and Factory Systems Business Unit		Project Reports from the Virtual Engineering Expert Group	
		A Study of Innovations in Medium- sized Enterprise Networks: Success Factors and Methods	36	Virtual Optimization and Commissioning of a High Temperature Wood Drying Kiln	58
		Fifteen Small and Medium-sized Enterprises on the Road to Knowledge Management	38	VIDET: Fraunhofer Virtual Development, Engineering and Training Innovation Cluster for Regional Large Machinery and Plant Manufacturing Industry	60

Examples of Applications from the Fraunhofer VIDET Innovation Cluster	62	Project Report from the Central ViVERA Office		Highlights, Events and Trade Fair Presentations in 2007 (Selection)	97
Automatic Generation of Multibody Models: A Contribution to Integrated Virtual Engineering	64	ViVERA Network of Competence for Virtual and Augmented Reality	86	Appendix: Names, Data, Publications	
Hollow Profiles for State-of-the-Art Lightweight Construction	66	Project Reports from the Process and Plant Engineering Business Unit		Saxony-Anhalt Center for Renewable Energies ZERE	120
Project Reports from the Virtual Prototyping Expert Group		Generating Virtual Interactive Scenarios to Visualize Process Equipment Process Parameters	90	Committee Work in 2007 (Selection)	122
Service of the Future: Interactive 3-D Operator Manuals	70	Integrated Process Systems to Recover Energy from Biomass in Fuel Cells	92	International Research and Cooperation Partners in 2007 (Selection)	125
Interactive 3-D Visualization: Detailed Bathroom Planning	72	Development of a Compact Fluidized Bed Firing Plant for Low-emission Combustion of Biomass	94	Publications in 2007 Monographs and Editorships (Selection)	129
Virtual Technologies Represent Complex Markets	74			Articles and Papers (Selection)	129
				Presentations (Selection)	135
Project Reports from the Virtual-Interactive Training Business Unit				The Fraunhofer-Gesellschaft at a Glance	
Using Computer Simulated Production Scenarios to Sustainably Organize Production Processes	78			The Research Organization	140
High Voltage Equipment Maintenance: The Challenge of Qualifying Technical Experts	80			Fraunhofer IFF Contacts at a Glance	143
Product Development Based on a Semantic Virtual Engineering Environment	82			Editorial Notes	146

Foreword



Prof. Michael Schenk
Director of the Fraunhofer Institute for
Factory Operation and Automation
Photo: Viktoria Kühne

Esteemed Ladies and Gentlemen,
Dear Business Partners and Friends,

The famed Thomas Alva Edison brought it to a point: "Everything comes to him who hustles while he waits." It's as if these words were meant for the researchers at the Fraunhofer IFF in Magdeburg. Thanks to their researching spirit and dedication, we are able to look back in 2007 on fifteen years full of research projects with abundant results and steady growth. All of our projects share one commonality: State-of-the-art technological innovations ought to simplify and improve people's lives.

Since our founding in 1992, we have been pursuing the goal of planning and operating factories and production systems more efficiently. We perform applied research and development in the fields of virtual engineering, logistics, automation and process and plant engineering. From idea finding to implementation up through employee training, we provide comprehensive and customized research and development services to our clients and partners.

We have achieved much in our short but dynamic history. In these fifteen years, we have jointly launched the application of many new developments with our industry partners. Our clients confirm our remarkable balance of successful collaboration: Over 60 percent of our project partners are so satisfied with the quality and utility of the joint research work that they repeatedly contract specialists from the Fraunhofer IFF for their ambitious projects. There is no difference whether this is a spinoff, small and medium-sized enterprise or internationally operating concern. Hence, I would like to expressly

thank all of our partners for the confidence they have placed in us in the past and the invaluable experiences from our joint project work.

We have been able to occupy our second new building in eight years, our Virtual Development and Training Centre VDTC, thanks to our staff's incessant striving for innovation and their enthusiasm for research and new technologies. Apart from perpetually watchful curiosity, courage and an open mind are also sometimes part of treading the paths to unconventional solutions.

Not only our industry partners but also government pays extremely close attention to the Fraunhofer IFF's work and impact. In an extra eponymous special issue of the *Wirtschaftsspiegel* published on the occasion of the fifteenth anniversary of the Fraunhofer's presence in Saxony-Anhalt, Minister President Wolfgang Böhmer emphasizes the significance of the Fraunhofer IFF for this center of business: "Especially by opening of its Virtual Development and Training Centre VDTC one year ago, the IFF Magdeburg has clearly been able to gain potential and quality. The possibility to profit from applied and industry research directly on site is a great advantage equally for investors and entrepreneurs, which is often decisive for competition." Minister of Economics and Labor Reiner Haseloff recognized the Fraunhofer IFF in the same publication: "This institute is a jackpot for Magdeburg, for Saxony-Anhalt."

What praise! Clearer words for our Fraunhofer Institute's success and significance are hardly to be found. This will be our incentive in the future.

The national government has also given the work at the Fraunhofer IFF considerable attention: In April 2007, Minister of Finance Peer Steinbrück visited the VDTC in Magdeburg's Port of Science. Before him, national officials have repeatedly visited to look into our researchers capabilities, for instance, former Minister of Finance Hans Eichel in 1999, Federal Minister of Education and Research Edelgard Buhlmann in 2002 and even the German Chancellor Dr. Gerhard Schröder in 2004. In February 2006, the Federal Minister of Transport, Building and Urban Affairs came as one of the first visitors to the VDTC, which was still a shell at that time.

When we moved into the VDTC, where our experts are primarily devoted to researching and developing virtual technologies and their potential applications, we created space urgently needed for the fields of logistics and automation in our institute building on Sandtorstrasse. With our LogMotionLab, a development, testing and certification lab for auto-ID and telematic technologies, we have one of Europe's best equipped RFID labs at the Fraunhofer IFF. Our best known export is undoubtedly the IFF Smart Box: Since 2007, the DHL Innovation Center, Deutsche Post World Net's future lab in Troisdorf near Bonn, has been displaying this joint development as an example of new, marketable products with a particularly high level of innovation.

We are using the capacities in our main building's testing facility freed by the move to further expand our LogMotionLab and for new projects in robotics and optical 3-D metrology.

With its development of automated cleaning and inspection systems for the Emscher sewer system, the Robotic Systems Business Unit is completing one of the largest industry projects in the Fraunhofer-Gesellschaft. At the same time it is starting to set up a human-robot interaction lab that will particularly deal with projects from the life science sector.

The Measurement and Testing Technology Business Unit develops contactless optical 3-D measuring systems that even meet the strict requirements of the Deutsche Bahn and its measurement and calibration division.

In March of 2007, our Process and Plant Engineering Business Unit started a project with enormous strategic importance for the entire Fraunhofer world. As part of the Pact for Research and Innovation, both the Max Planck Society and the Fraunhofer-Gesellschaft announced they would deepen their diverse existing cooperations. The research organizations' joint projects are intended to accelerate processes of innovation by closely combining basic and applied research. One of the first projects in Germany, ProBio, is starting in Magdeburg. Together with researchers from the Fraunhofer Institute for Ceramic Technologies and Systems IKTS in Dresden, Magdeburg's researchers from the Fraunhofer IFF and their colleagues from the Max Planck Institute for Dynamics of Complex Technical Systems are researching the effective and environmentally compatible use of renewable raw materials to produce electricity.

We are especially proud of the confidence the Federal Government and the Fraunhofer-Gesellschaft have placed in our experts' capabilities in the field of

virtual development and training at the VDTC: The Virtual Development, Engineering and Training (VIDET) Innovation Cluster opened in October of 2007. This innovation cluster is intended to further develop the machinery and plant manufacturing industry's already existing business potential, promote new product ideas and safeguard jobs. The starting point for the promotion of such regional clusters by the Fraunhofer-Gesellschaft is the Bund-Länder Commission for Educational Planning and Research Promotion's resolutions of November 2004 and June 2005 for the Pact for Research and Innovation and the Excellence Initiatives for Institutions of Higher Education.

This annual report will inform you extensively about the research work and the commitment of the people at the Fraunhofer Institute for Factory Operation and Automation IFF in Magdeburg. I invite you to discover in detail on the following pages how we have developed new products and services together with our partners. Perhaps it will be a source of one inspiration or another – we would then be pleased to stand by you to make your vision reality.



Prof. Michael Schenk

Greeting



Michael Reinboth
Project Manager of DHL Hub Leipzig GmbH
Photo: Viktoria Kühne

Developing “Rapid Logistics” with the Aid of Research

The region around Leipzig/Halle Airport is intended to and will evolve into a “rapid region for rapid logistics”. Together with the neighboring freight center, the tri-modal transshipment node at the airport, which has equally good air, road and rail connections, provides the best prerequisites for this. No other location is as centrally located in Europe. Speed and location have to become a unique selling point. Its development will require and create many jobs, which our region urgently needs. However, this will only be a lasting success if, on the one hand, sufficient young academically trained professionals are present and, on the other hand, state-of-the-art technologies are used, which create further advantages and edges for this location in the global competition raging here as well. Our competitors in this struggle for global rapid logistics nodes are powerful, Dubai being but one example. Local competition is absolutely not at all conducive here ...

Rapid logistics need a boost of innovation. Therefore, as one of the enterprises shaping the structure in Leipzig/Halle, DHL decided to collaborate with the Fraunhofer IFF in Magdeburg. Requirements arising in the field can be acted upon innovatively and. The envisioned use of RFID technology to control more than 1,500 airfreight containers moved at night exemplifies this.

If we intend to live up to our reputation as the “region for rapid solutions”, this project will also have to be pushed ahead rapidly. We need solutions that can be implemented rapidly and quickly unfold their impact. Not the research “birds in the bush” delivered after years counts for us but rather a solution-oriented “bird in the hand” produced with research. In the face of continually rising energy prices and the challenges of global climate change as the number of transports continually increases, innovations in logistics are in demand more than ever.

We have found the right partner for this path in the Fraunhofer Institute for Factory Operation and Automation IFF in Magdeburg. Fraunhofer and logistics have always been a good match. This will also function in the combination of airport - DHL - IFF. Pragmatism and practical orientation have always characterized Central Germany and it is incumbent to develop these traits even more in the future, to the benefit of business and research.

DHL will also continue alongside the Fraunhofer IFF, not only but also on its Advisory Board. Naturally, it is a special honor for a native of Halle to support an organization in the capital in an advisory function!

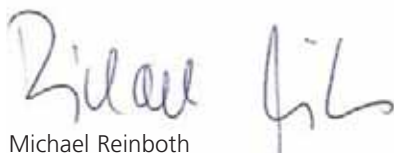

Michael Reinboth

Mission

The Fraunhofer Institute for Factory Operation and Automation IFF is an autonomous research institution in the Fraunhofer-Gesellschaft's network.

As a regional, national and international partner, the Fraunhofer IFF's mission is to use its applied research work to contribute to directly benefiting the economy and of society.

The institute is technologically oriented toward designing, engineering and producing innovative and customized solutions in the fields of

- Logistics and Material Handling Engineering and Systems,
- Robotic Systems and Measurement and Testing Technology,
- Process and Plant Engineering and
- Virtual Engineering and Virtual Training.

Work at the Fraunhofer IFF is market driven and global.

To meet the demand for holistic solutions, the Fraunhofer IFF is integrated in an international research network of partners from scientific and business communities.

A network of associated academics and representatives of leading industries actively supports the work of the Fraunhofer IFF in order to guarantee an ongoing exchange of knowledge and experience through our own creativity and external impulses.

The Fraunhofer IFF actively represents interests in national and international bodies in specialized fields and thus fundamentally shapes the processes of innovation in the state of Saxony-Anhalt.

As a research service provider based in Saxony-Anhalt, one important concern is developing future generations both for regional business and for challenging positions in academia and research. Thus, the Fraunhofer IFF fulfills a valuable social responsibility.

Striking a balance between economy and ecology as well as implementing the rules of excellent scientific and technical practice are the basis for all our researchers' work and an individual commitment.

Our researchers' combination of technical and technological expertise and soft skills typify the quality of our products and services.

Our researchers work in interdisciplinary teams and cooperate closely with our clients. Such collaboration is characterized by mutual trust, integration as partners, practical application and user orientation.

The Institute in Figures

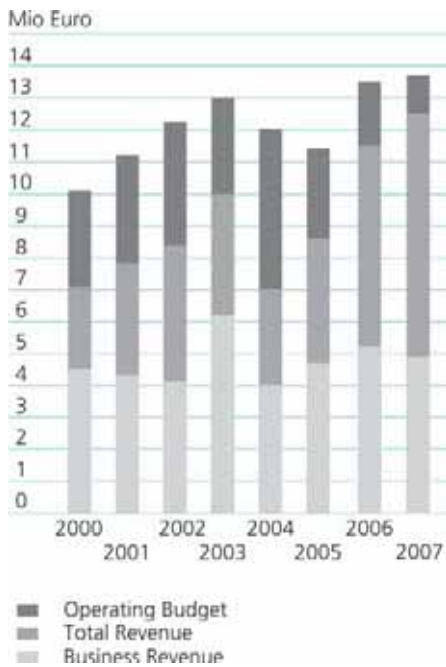

Operating Budget and Earnings Trend

In 2007, operating budget expenditures totaled 13.7 million euros. Total revenues were 12.5 million euros and business revenues were 4.9 million euros.

Investment Budget

Investments totaling 452,000 euros were made in 2007.

Personnel Development

At the end of 2007, the Fraunhofer IFF had 143 employees. Our researchers are predominately engineers and industrial engineers. Degree holding computer scientists, mathematicians, physicists and business people ensure our work is interdisciplinary.

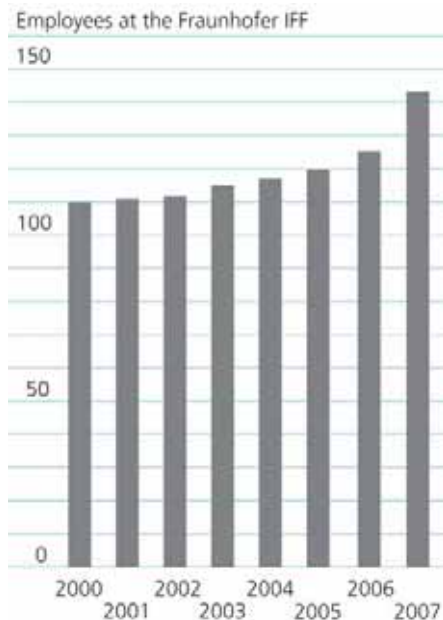

Training and Qualification

Over 270 student assistants and interns support the institute's work.

Fourteen Diplom and three doctoral candidates given advising at the Fraunhofer IFF in 2007.

We offer internships for institutions of continuing education and high schools.

Facilities

In its main building on Sandtorstrasse, the Fraunhofer IFF in Magdeburg utilizes 5.000 m² for office space and high-tech EDP labs and conference rooms. A testing facility of 1.300 m² provides technologies – RFID and telematics, industrial image processing, robotics and rapid prototyping – for research and development.

At the VDTC in the Port of Science, the Fraunhofer IFF additionally has 2.755 m² of floor space (including the testing facilities, labs and offices) for technologies of virtual and augmented reality as well as process and plant engineering. The heart of the VDTC is its large projection system, the Elbe Dom with cylindrical 360 degree laser projection surface of 327 m², a diameter of 18 meters and a height of 6.5 meters.

Hardware and software at the Fraunhofer IFF encompasses tools and environments for the application of geographic information systems, for idea generation and evaluation, for information and communications management, for interactive factory and systems engineering, for multimedia communication and for software development.

Advisory Board

The individual Fraunhofer Institutes' advisory boards support institute management and the Fraunhofer-Gesellschaft's executive board in an advisory capacity. Members include prominent figures from academia, research, business and government.

Chairman of the Advisory Board

Prof. Burghard Scheel

Member of the Harz AG Advisory Board

Vice-Chairman of the Advisory Board

Prof. Uwe Dombrowski

Technical University of Braunschweig

Guido Brassart
Georg Maschinentechnik GmbH &
Co. KG

Dr. Frank Büchner
Siemens AG

Peter Claussen
BMW Plant Leipzig

Dr. Udo Häfke
Innovations- und Gründerzentrum
Magdeburg GmbH

Hans-Joachim Hennings
Saxony-Anhalt Ministry of Economics and
Labor

Dr. Klaus Hieckmann
SYMACON GmbH

Dr. Hans-Jürgen Hühne
Deutsche Telekom AG

Prof. Albert Jugel
Dräger Safety AG & Co. KG a.A.

Volker Oesau
DHL Danzas Air & Ocean GmbH

Prof. Klaus Erich Pollmann
Otto von Guericke University Magdeburg

Michael Reinboth
DHL Hub Leipzig GmbH

Dr. Robert Ruprecht
Forschungszentrum Karlsruhe GmbH

Richard Smyth
Airbus S.A.S

Dr. Joachim Welz
Saxony-Anhalt Ministry of Education
and Culture

Prof. Peer Witten
Logistics Initiative Hamburg c/o
Behörde für Wirtschaft und Arbeit

Thomas Zernechel
Volkswagen AG



Attendees of the 2007 Advisory Board meeting in Magdeburg (l. to r.):
Dr. Udo Häfke, Hans-Joachim Hennings, Michael Reinboth, Dr. Joachim Welz, Peter Claussen,
Dr. Klaus Hieckmann, Prof. Klaus Erich Pollmann, Prof. Burghard Scheel, Prof. Peer Witten,
Guido Brassart, Prof. Ulrich Buller (guest), Dr. Hans-Jürgen Hühne, Prof. Michael Schenk,
Thomas Zernechel, Dr. Frank Büchner, Richard Smyth, Dr. Hendrik Gorzawski (guest).
Photo: Viktoria Kühne



Career Start at the Fraunhofer IFF: European Training Program for Young Researchers

Dr. Eberhard Blümel

A training program for young researchers funded by the EU as part of its Marie Curie Actions is successfully underway at the Fraunhofer IFF Virtual Development and Training Centre VDTC. During the runtime of four years, twelve young researchers will come to the Fraunhofer IFF from inside and outside Europe. These young talents are working on international research projects and acquiring practical experience in industry projects in "Research Training@VDTC". One, two and three years residencies are offered,

which the Marie Curie Fellows can finish with a Master's or doctorate, depending on the length of time they spend here and their interests. The program's thematic foci encompass the innovative field of applied virtual reality and virtual engineering. Three thematic fields may be selected:

- Virtual product development,
- Virtual process control and
- Virtual interactive training.



Kamil Lipiec, Poland
Photo: Dirk Mahler



Izabela Sewerynek, Poland
Photo: Dirk Mahler



Sergii Kolomiichuk, Ukraine
Photo: Dirk Mahler



Ling He, China
Photo: Dirk Mahler



Rui Guimaraes, Portugal
Photo: Viktoria Kühne

The project "Research Training@VDTC" is being supported by the European Union. (Reference No. 20722)

The young researchers attend classes at the university and research in the institute's labs outfitted with high-tech equipment, e.g. the LogMotionLab or the Elbe Dom with its 360 degree projection surface. Soft skills modules, language courses and conference attendance supplement their training. The program is being implemented in cooperation with Otto von Guericke University Magdeburg and regional industry partners. The objective of the training program is to familiarize young researchers, based on their

existing expertise, with the latest virtual and augmented reality technologies and to enable them to develop new methods to apply these technologies in practice.

To this end, an individual personnel development plan defining long-term and short-term goals for future career development and measures for their achievement is developed for every Marie Curie Fellow. These may range from specifying detailed training contents to planning the publication of research

findings at international conferences to acquiring management skills for research and development projects. An important step in this direction is the young researchers' integration in project teams so they can collaborate on European research projects or acquire practical experience in industry projects. The Marie Curie Fellows at the Fraunhofer IFF are pictured on these pages:



Charikleia Sermpetzoglou, Greece
Photo: Viktoria Kühne



Tamas Juhasz, Hungary
Photo: Viktoria Kühne



Carlo Belardinelli, Italy
Photo: Viktoria Kühne

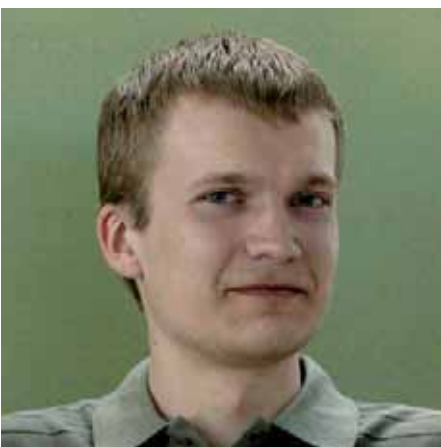

Ivan Pechenizkiy, Ukraine
Photo: Bettina Rohrschneider



Svitlana Budza, Ukraine
Photo: Dirk Mahler



Bartlomiej Arendarski, Poland
Photo: Viktoria Kühne

Project Reports from the
Robotic Systems Business Unit

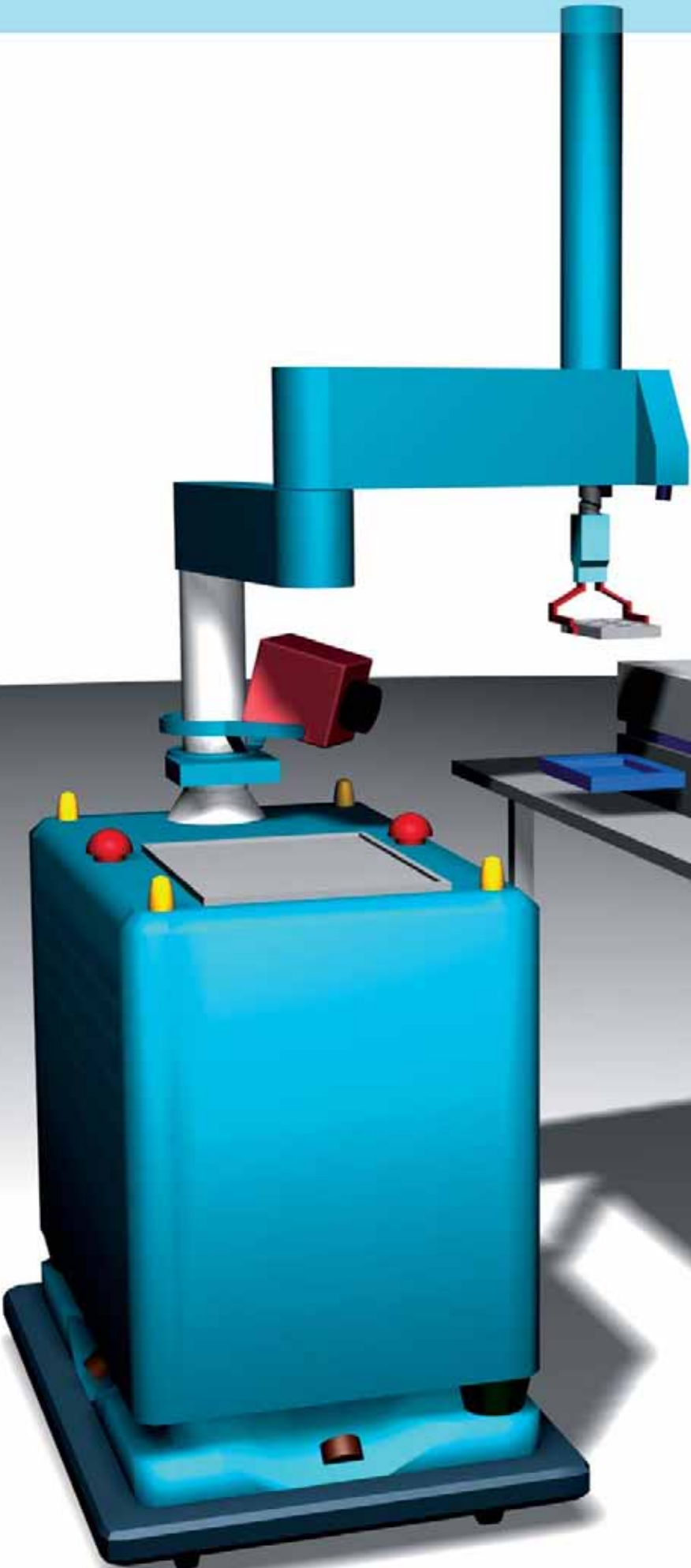



New Fields of Application for Industrial Robots: Casting Models and Molds for Prototyping

Torsten Felsch
Tel. +49 391/40 90-223
Torsten.Felsch@iff.fraunhofer.de

Initial Situation

Small and medium-sized enterprises are increasingly facing the challenge of even manufacturing small batches as customized as possible and require highly flexible production resources to do so. Given the high costs of making casting forms and models, long established foundry technology has only been cost effective for medium and large batches. Using a model to produce cast parts does not allow rapid conversion to new products since making casting forms and models requires intense time and labor. Model making incurs up to 90 percent of the product costs for prototypes and small batches. That is why only mass casting is cost effective.

Alternatively to this conventional process, sand molds for prototyping and small batch production are increasingly being made directly using cost-intensive CNC milling machines and generative processes. Milling with CNC tools guarantees extremely high accuracy of shape, yet is connected with numerous drawbacks.

On the one hand, the space extremely limits the molds that can be milled and, on the other hand, their compact design makes the machines difficult to access. Another drawback is the increased wear on machines from sand milling caused by the abrasiveness of sand dust in the guides. Generative or so-called rapid processes build up a sand mold layer by layer and harden it by heating the binder in the sand. Primarily Croning sand is selectively laser sintered. Just like CNC this is also connected with a number of drawbacks. Only very small but nonetheless complex molds can be built up. A great deal of time is required to build up the layers and harden them with a laser. The diminished casting quality due to the large amount of binder laser sintering requires in the sand is especially negative

Consequently, model and form making need to be optimized considerably if alternative methods of model and form making are to be used for prototypes and small batches.



The project "RoboCasting" was supported by the state of Saxony-Anhalt .
(Reference No.: 6003276501,
Grant No.: 0604/00027)

Fig. 1: Milling application with an industrial robot. Photo: Torsten Felsch

Approach

The research project "RoboCasting" developed and tested methods and processes to cost effectively make large-volume casting molds and models

On the one hand, the solution involves using industrial robots to directly mill the casting molds, as a result of which time and labor consuming models can be dispensed with. On the other hand, a novel process is being developed to generate casting models approximating the final mold in layers, which is based on the rapid prototyping process of "fused layer modeling".

Customized, large-volume cast parts (principal dimension > 2.5 meters) are produced based on 3-D datasets of a cast blank provided by or jointly developed with a client. The 6-axis robot's large clearance and great flexibility can especially be taken advantage of when large and complex molds are being produced. The robot's rugged engineering makes it ideal for sand milling and use directly in foundries

The transferability of the technological process of milling to industrial robot systems was tested. The machining forces active during sand milling have been adapted to robot use by optimizing the tool design, feeds, immersion depths, etc. have adapted. When a path is planned, standardized 2.5 and 5-axis motion data is converted from CAM programs into 6-axis motion sequences for industrial robots. Robot cell operation is oriented toward common machine tools, thus achieving greater acceptance when used in industry. A standard industrial robot from KUKA Roboter GmbH running CAMRob software constitutes the basis of the system

To adapt the rapid prototyping process to an industrial robot to make models generatively, an automatic dispenser nozzle for PU foam and path planning software were developed. They have been initially tested and optimized.

Results and Benefits

The innovation is the utilization of precisely operating industrial robots to rapidly machine complex casting molds and models for prototyping and small batch manufacturing. Compared with conventional machine tools, robotic machining provides a larger working area and more flexible casting molds and models at a fraction of the cost. Directly making molds and models with a robot enables producing prototypes or components in short time. This is particularly important for the growing field of simultaneous engineering, which increasingly needs prototypes..

The industrial robot's six degrees of freedom allow additional options for cast part design, which were hitherto impossible. Thus, draft angles can be dispensed with entirely and a mold can be divided more complexly, optimally adapted to the cast part. A cast part largely does not have to be reengineered for casting. Furthermore, molds can be machined on five sides.

The combination of generative model making with subsequent machining opens completely new possibilities for model making and the foundry industry.



Fig. 2: Milled sand mold.
Photo: Torsten Felsch



Fig. 3: Laminate model making combined with milling afterward.
Photo: Torsten Felsch

Project Partner

- Modell- und Formenbau GmbH
Sachsen-Anhalt, Magdeburg

Interactive Human and Machine: Service Robot LISA Cooperates with Humans in Labs

Dr. Norbert Elkmann
Tel. +49 391/40 90-222
Norbert.Elkmann@iff.fraunhofer.de

Motivation

Robots are already supporting humans today. Industrial robots have been successfully performing their jobs for years. They take over a wide variety of tasks they are often able to complete far better, more precisely and more reliably than humans.

However, humans and robots still do not directly interact in common work areas. Research on robotic systems that allow interaction between humans and robots is being pursued throughout the world. The goal is a multifunctional robot for everyday routines that moves freely in its surroundings, interacts with humans and performs its job autonomously.

The Project

Together with established research and industry partners in a collaborative project funded by the Federal Ministry of Education and Research, the Fraunhofer IFF as coordinator and project partner, is developing LISA, a robot that will operate in the life science sector and interact with lab technicians. LISA is intended to take over routine and transport tasks in scientific labs and independently load the different measuring and test stations. All the while, the robot will intensively interact with the human staff with which it also shares the work area.

The majority of work in biotechnological and pharmaceutical research, particularly

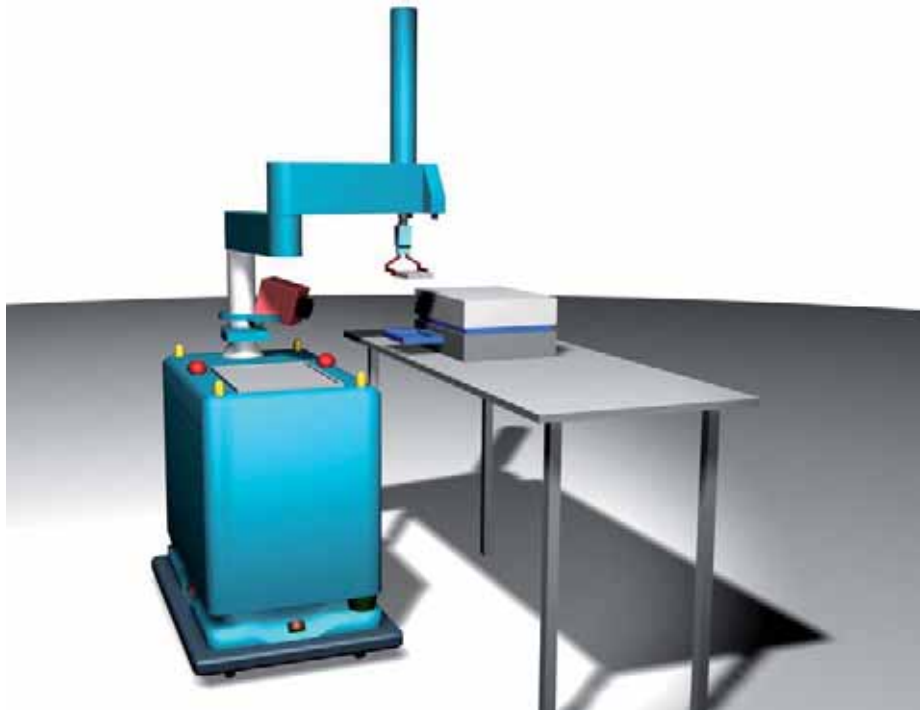

Fig. 1: The service robot for the life science sector.

This research and development project is being supported by the Federal Ministry of Education and Research (BMBF) within its framework concept "Research for the Production of Tomorrow" (Project Reference No. 02PB2170 to 02PB2177) and supervised by the Project Management Agency Forschungszentrum (PTKA-PFT) in Karlsruhe.

the preparation of tests and loading of specific stations, e.g. incubators, microscopes, autoclaves and pipetting stations, still has to be performed manually.

LISA can be used to flexibly interconnect stations. New stations (instruments, etc.) can easily be integrated into the workflow without having to retrofit or expensively upgrade and integrate a stationary automated station. Along with reducing work for staff, which is harmful or critical to health, LISA minimizes the risk of contamination from specimens and improves sterility.

Above all, flexibility, intuitive operability and safety are crucial to the acceptance of a mobile and autonomous assistant robot such as LISA so intensively integrated in the rhythm of the lab staff's work. Hence, these aspects are particular priorities during its development. That is why a decision was made for the most expedient variant in terms of operability. The choice fell on multimodal interaction based on natural speech input and output as well as a display with intuitive user navigation. Staff members use this to easily communicate with the assistant robot in complete sentences, while it addresses its human colleagues the same way.

Special attention is being paid to the safety requirements. Fulfilling them is a basic prerequisite to the use of the robot as intended. This not only concerns protecting lab staff from being pinned or hit by the mobile platform and the manipulator but also preventing small glass bottles of chemicals or other lab utensils from being knocked over. Hence, an extensive safety sensor system is integrated in the LISA assistant system.

Developing the inherent safety of the manipulator, i.e. the robot's action arm, was particularly complicated and involved. It is outfitted with various collision detection and avoidance systems so that its movements neither harm humans nor materials. Camera data and sensors are used to precisely coordinate every movement. Whether an obstacle, e.g. a hand or object, occupies the target area is checked during every procedure. If this is the case, the system reacts immediately by stopping or taking evasive action.

LISA is additionally furnished with a "tactile skin", one of the Fraunhofer IFF's own developments. This is a pressure-sensitive surface that precisely informs the system where there is contact and how intense it is. It is an extremely elegant and innovative solution to a special problem, which will enjoy further application.

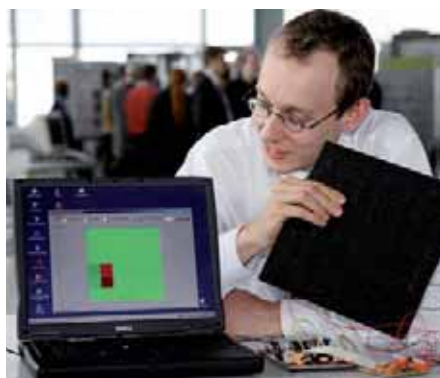

Fig. 2: The "tactile skin" is a development of the Fraunhofer IFF. Photo: Viktoria Kühne

Outlook

The project's prospects for success have been assessed as exceedingly positive. Biotechnology is one of the key technologies of the twenty-first century with corresponding significance for the economy. While a large number of life science companies have established methods to increase throughput, many are not yet able to implement such commercial approaches. Their workflows and test series often vary widely and frequently must be quickly adapted to current test results. The use of assistant systems such as LISA is far more expedient for such firms than other automated systems or strategies to increase throughput and effectiveness. Their autonomous and highly flexible use in time and space makes such systems particularly efficient, frees lab technicians from relatively unproductive transport tasks and makes lab work possible around the clock. In addition, it relieves staff from work harmful to health and ensures tests are conducted continuously and reproducibly. It promises optimal conditions to adhere to scheduled times in test procedures and potential for flexible and efficient applications - from single tests to high throughput operation. Moreover, it does so with the same lab layout while improving lab conditions for sterility and preventing the risk of contamination.

Use of the assistant robot LISA in the field will become reality in the foreseeable future. Its development is only the first step toward further generations of robot systems that we will also soon encounter in everyday life.



A Virtual Environment to Overcome Interdisciplinary Barriers to the Use of Lab Robots

Dr. Oliver Lange
Tel. +49 391/40 90-219
Oliver.Lange@iff.fraunhofer.de

Steffen Masik
Tel. +49 391/40 90-127
Steffen.Masik@iff.fraunhofer.de

Christian Herker
Tel. +49 391/40 90-276
Christian.Herker@iff.fraunhofer.de

Annedore Rössling
Tel. +49 391/40 90-276
Annedore.Roessling@iff.fraunhofer.de

Motivation

Robotics is increasingly seeking markets outside the classical fields of application in machinery manufacturing or the automotive industry. Biotechnology and life science have been being equipped with lab robots for years. However, since most lab specialists are usually not programmers, another technological gap exists between robot manufacturers and users.

Robotics is facing a market familiar with the advantages of robot use. Users view robot use extremely critically though since the requisite human resources and proper specialized knowledge are usually not adequately available. Adapting robot programs to changing processes is considered "difficult" and "cost-intensive". Yet, protracted adaptation times are unsuitable for industries in which scientific progress requires rapid process adap-

tation. Therefore, the project "LARA" is intended to identify a solution that virtually assists users when they are programming lab robots.

Approach

The project "LARA" set up a virtual work environment as a lab. It provides the objects (pipettes, microplates, fluids, etc.) and enables users to conduct experiments virtually in the manner to which they are accustomed to from their daily routines. The virtual lab's VR input interface records the experimental procedures. This recorded information is analyzed in a second step and translated into the robot's language by a compiler. The literature refers to such a solution as "task demonstration" or "programming by demonstration".

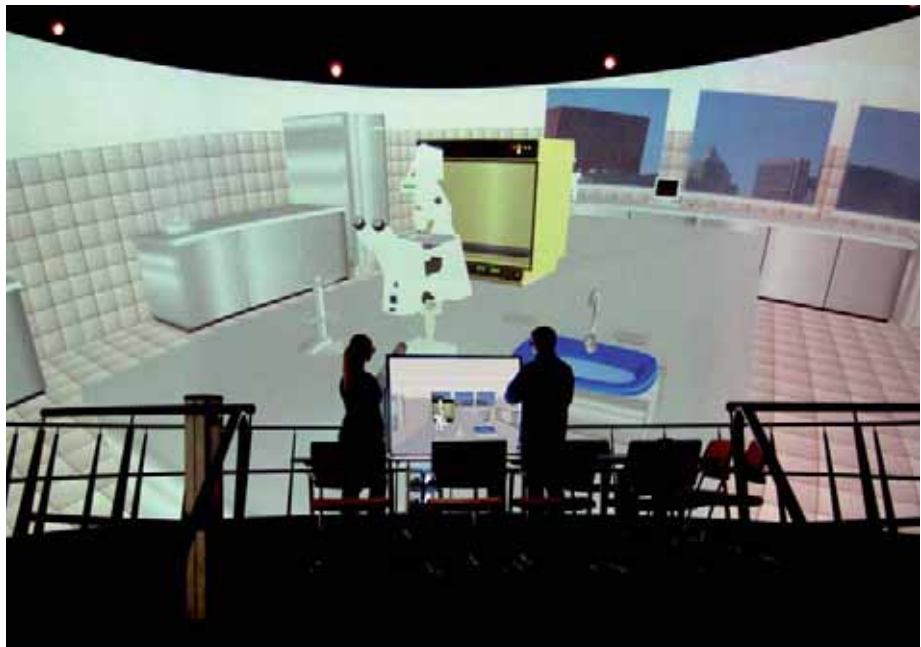

Fig. 1: A virtual lab in the Elbe Dom's large projection system at the VDTC. Photo: Steffen Masik

The state of Saxony-Anhalt is supporting "LARA" as part of the project "TecViCom: Technology Platform for Virtual Commissioning". (Reference No.: 6003277808)

The compiler is the key element of this approach. Whence does it know what procedures need to be translated into robot commands? What robot commands are forbidden in what context? Lab robot manufacturers are already investing much development work in suitable development tools. These tools continue to be necessary because they enable combining the commands for the robot into individual "words". Often denoted as "macros" or "methods", these larger components capture and monitor factors specific to the instruments, e.g. once a liquid has been taken up, it must be dispensed fully before a second pipetting step can follow. It is up to the instrument manufacturer to decide how this should be done. Thus, the robot's language cannot consist of the smallest units of a command as in ordinary control system engineering, e.g. "move the robot 3 mm to the left". Rather, given the ancillary technical conditions, it must operate on the basis



Fig. 2: The virtual metaphor "96 pipette" simplifies the programming of lab operations.

of a language of "macros" and "methods". Consequently, information from two different disciplines must be fused:

- Biological/chemical experiments and knowledge of the required procedure and
- Conditions for automation.

As a precondition to pursuing both lines of development, lab procedures first had to be abstracted, concentrating on pure liquid handling procedures that constitute the majority of lab procedures. These procedures were formalized, producing a list of actions and objects in an interaction matrix covering every single procedure possible. More complex instruments (measuring instruments, incubators) were reproduced as a generic interface that relays preformulated programs from the virtual environment.

These levels of abstraction can be used to specify the virtual lab as well as the compiler. Information from the configuration of the real robot was additionally incorporated into both components: Thus, virtual reality may only provide those objects for which the robot has an analogy on hand. In addition, the compiler may only translate into the existing scope of the robot's commands. Virtual systems facilitate the application of an intuitive intermediate solution for simplification. Thus, for instance, to eliminate cyclical procedures prone to failure, a really nonexistent 96 pipette was developed that is operated analogously to multipipettes. Such "metaphors" must be intuitively comprehensible and based on established lab concepts.

Results and Benefits

The objective of the project was to demonstrate that further development of such programming aids with the help of virtual technologies is possible and expedient. Concepts were tested to demonstrate the implementability of this approach in a given robot programming task.

Virtual technologies enable end users to program complex technical systems for liquid handling lab robots without requiring additional training as programmers. Taking life science as an example, virtual reality was proven to a tool that eliminates barriers in interdisciplinary sectors.

Outlook

The application of virtual environments to reproduce lab processes extends beyond pure robot programming. Upgraded software will support the documentation and technical specification of many lab procedures in the future. Such compilations of experiments provide the basis for clear technical descriptions of lab processes. Hence, this approach can also be used in sales to determine a robot's configuration on the basis of lab procedures. Thus, if they greatly reduce a robot's complexity, changes to a procedure could be proposed virtually.

Project Reports from the
Measurement and Testing Technology Business Unit



Engineering and Commissioning of Optical Dimensional Inspection Systems for 3-D Manufacturing Metrology

Silvio Sperling
Tel. +49 391/40 90-232
Silvio.Sperling@iff.fraunhofer.de

Michael Schiller
Tel. +49 391/40 90-242
Michael.Schiller@iff.fraunhofer.de

Dirk Berndt
Tel. +49 391/40 90-224
Dirk.Berndt@iff.fraunhofer.de

Motivation

The use of automated optical measurement and inspection systems has steadily increased in recent years. As the number of such systems has grown, their complexity has also increased continuously. Multi-camera arrays, coupling with motion systems or robots, combinations of the widest variety of sensor principles and simultaneous handling of several inspection tasks in ever shorter time are properties of state-of-the-art systems. The steadily growing number of three-dimensional measurement and inspection tasks is additionally increasing the complexity of these systems.

The effects on the development process are many and diverse. An ever larger number of technical disciplines such as mechanical engineering, technical optics, computer science, electrical engineering, and design are involved in development. The increased interdependence of technical disciplines necessitates far more intensive communication and greater information exchange than earlier.

Every technical discipline has its own development tools at its disposal. This complicates the exchange of data between disciplines. Individual technical disciplines' tendency to execute stages of development consecutively has ramifications for the development process. This adversely affects the effectiveness of development work. This is neither desirable for the quality of a final system or ever shortening development times, two factors that significantly influence companies' competitiveness.

Objectives

The objective of this research project was to create an integrative simulation tool for technical disciplines, which can be employed to develop automated optical measurement and inspection systems more effectively and rapidly. The simulation tool is not intended to replace the technical disciplines' highly specialized simulation tools. Rather, it facilitates the conjoint representation of individual results in a standardized system model. The model simulates an overall system's performance or aspects of it, making it possible for the first time to visualize the interaction of the partial developments from the individual technical disciplines. The technical disciplines involved can exchange requirements and solutions among each other in an early stage of a project. A simulation of an overall system's performance that incorporates external influencing factors provides dependable information on the reliability and dependability of the functions of a system being engineered.

The state of Saxony-Anhalt supported the project "OptoSim" as a subproject as part of the project "TecViCom: Technology Platform for Virtual Commissioning". (Reference No.: 0604/00034)

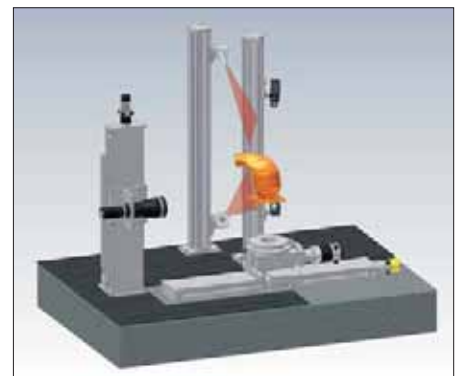

Fig. 1: Virtual model of an optical 3-D measuring machine.

Approach

The reproduction of every relevant component in a CAD environment is the starting point of a simulation. An initial design specifies the configuration of the requisite sensors, motion axes and the target. This data is then exported to the simulation software and previously unavailable information (e.g. camera resolution, surface properties of the target) is added. A variety of modifications can be made to the initial configuration (e.g. camera parameters, position) in the simulation environment and their effect on the quality of data acquisition tested. Once the initial configuration has been optimized to obtain high data quality, this information reenters the CAD model, which is appropriately modified so that the engineering process can continue with defined and validated components configurations .

As it proceeded, the project focused on individual selected emphases of development. These included the the:

- Importation of data from CAD systems,
- Completion of the model with non CAD information,

- Development of methods to generate parameterizable virtual image data and
- Development of methods to generate virtual point clouds for the needs of optical, dimension-measuring 3-D manufacturing metrology.

Results and Benefits

The project laid the foundations for an integrative simulation tool for technical disciplines that helps develop automated optical measurement and inspection systems more effectively and rapidly, enabling the technical disciplines involved to better exchange requirements and solutions in an early stage of a project. The simulation of an overall system's performance that incorporates external influencing factors provides dependable information on the reliability and dependability of the functions of a system being engineered.

The data generation process including the calculation of a 3-D point cloud can now be represented in a virtual environment. This is significant for applications in which the orientation of optical sensors relative to the target decisively

influence the result of measurement. The orientation can already be tested in a virtual model early on, thus accelerating the development process. This has beneficial effects:

- Shortened development times through parallel work,
- Elimination of several iterative development loops (trial and error principle),
- Early-stage verified information on the function and reliability of the overall system being developed,
- Enhanced reliability by systematically simulating potential influences on inaccuracy and disturbances.

Outlook

Further development of the tool shall entail improving the simulated reproduction of the physical processes of technical optics in measurement and inspection systems. This will include qualitatively enhancing virtually generated image data (photorealistic rendering) to more closely approximate the quality of real images.

Further developing the simulation software would make it possible to fully test and parameterize real optical, dimensional measuring machines in the future. Thus, specific features of a machine could already be investigated in the development phase. Sequential measurement programs could already be produced in a virtual model. This would allow shortening its commissioning time and prevent downtimes in later operation.



Fig. 2: Camera image produced on the basis of the virtual machine model.



Fig. 3: Point cloud calculated on the basis of the virtual machine model.



Fig. 4: Original point cloud.

3-D Visualization of Readings in Optical Manufacturing Metrology OptoInspect3D®

Erik Trostmann
Tel. +49 391/40 90-220
Erik.Trostmann@iff.fraunhofer.de

Michael Schiller
Tel. +49 391/40 90-242
Michael.Schiller@iff.fraunhofer.de

Dirk Berndt
Tel. +49 391/40 90-224
Dirk.Berndt@iff.fraunhofer.de

Initial Situation

The adherence to geometric dimensions is an important criterion for quality assurance in manufacturing. Thus, the exact measurement of workpieces and subsequent, objective evaluation of the results of measurements are critical factors in the manufacturing process.

In 2002, the Fraunhofer IFF developed and delivered an optical 3-D measuring device for converter assemblies (catalytic converters including their housing and attached parts) to Volkswagen AG. Called OptoInspect3D®, this measurement technology allows rapid and flexible offline inspection of geometry in the manufacturing process. The result is a measurement dataset available as a 3-D point cloud for further processing.

Functional dimensions (e.g. lengths, diameters, angles) and predefined geometry (e.g. planes, spheres, cylinders) are automatically determined in the measurement data and compared with the reference CAD data. The equipment operator receives a measurement readout listing every dimension with its reference and actual data and tolerances. This enables reliable and objective good/bad decision making. However, given the multitude of three-dimensional shapes and dimensions, it was previously possible to generate correction parameters from this data for manufacturing to influence and control specific processes only with restrictions or the assistance of experts.

Solution Concept

The digitization of a converter assembly yields a dataset (point cloud) with several hundred thousand 3-D coordinates representing the points on an object's surface. Test specifications for every type of converter, which specify the methods and procedures to automatically extract geometric features from the 3-D coordinates and orient them in a vehicle's coordinate system are stored in a central database. Only after they have been oriented, can they be compared with the reference data (Fig. 1). Inspected features might include:

- Midpoints and orientations of inlet and outlet openings,
- Bores in flanges and holders or
- Positions of attachment bolts and supporting surfaces.

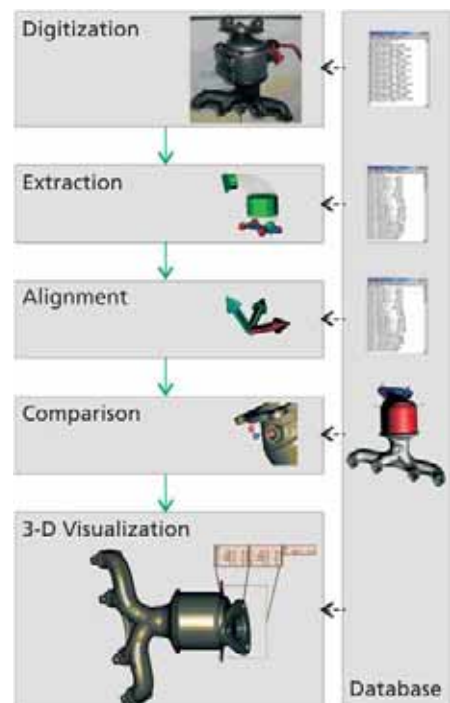

Fig. 1: Data processing structure.

Measuring accessories signal small bore midpoints and the position of threaded bolts to locate them more exactly in the point cloud. They are shaped like spheres or cylinders and system operators can easily and quickly add them to the pertinent features of inspection before digitization.

A core task was to abstract the readings from the measuring device sufficiently to make the results easily interpretable. The visualization of every 3-D coordinate would be too complex for an analysis that has to be executed quickly in a manufacturing setting.

Therefore, the CAD model solely represents the inspected features and their tolerances, symbolized by spheres and spatial axes. An operator can move an object under test in virtual space and

display deviations enlarged and magnified (Fig. 2). Templates are additionally used to visualize the distances between the features inspected as a further quality criterion. Thus, with the aid of the real converter assembly, the changes that must be made to correct errors can be estimated very precisely

Results

3-D visualization enables a system operator to not only purely inspect quality but also systematically draw conclusions about potential problems in manufacturing and quickly react. This new technology allows working faster and more intuitively than conventional measurement readouts.

Outlook

In the future, more detailed information on manufacturing will enter into the data analysis to develop a complete quality control loop. This will primarily affect existing adjustment options to correct errors in manufacturing equipment and data for the manufacturing process. This will enable drawing direct conclusions from the reading to make necessary modifications to manufacturing equipment while factoring in the degrees of freedom. Even the automatic transmission of such information to the manufacturing process is ultimately conceivable.

Project Partner

- VOLKSWAGEN AG, Kassel Plant Exhaust Systems Business Unit, Production Planning

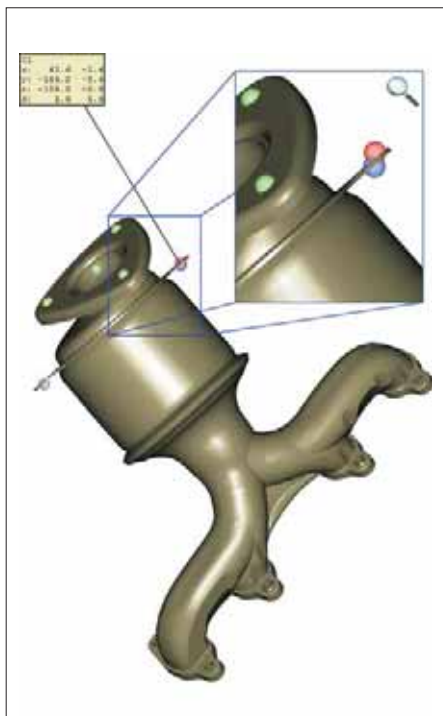

Fig. 2: 3-D visualization of a converter assembly's measured tolerances.

Moisture Detection System for Emission Measurements

Uwe Amreihn
Tel. +49 391/40 90-226
Uwe.Amreihn@iff.fraunhofer.de

Silvio Sperling
Tel. +49 391/40 90-232
Silvio.Sperling@iff.fraunhofer.de

Dirk Berndt
Tel. +49 391/40 90-224
Dirk.Berndt@iff.fraunhofer.de

Phase one of the project FMAS (Foundations for the Method of Measurement and Development of a Prototype Functional Model) was funded as part of the PRO INNO grant program, (Reference No.: KF 0000224 KMH1).

Phase two (Field Tests, Optimization of the Method of Measurement and Customer and Manufacturing-based Product Design) was part of an industrial product development phase.

Initial Situation

Protecting peoples' health and preserving the basic natural necessities of life requires considerable work preventing air and odor pollution of the environment. Objective and effective measurement, evaluation and assessment of these emissions from which measures for their reduction or elimination can be derived is the prerequisite to reducing air pollution. An essential part of any emission measurement is repeat measurement of the moisture in exhaust gas. This is especially true when the velocity and volumetric flow of exhaust gas are being exactly determined and the pollutant concentrations relative to dry exhaust gas measured. Taking isokinetic measurements with probes necessitates entering the measured moisture values as parameters in sensing equipment during the measurement itself.

Commercial moisture meters are only suited for only normal air compositions and gases free of particulates but not for such measurements. Moreover, they can only be applied to up to around 130 °C and at normal pressure. The goal of this project was to develop a mobile and manageable instrument suitable for the following technical parameters:

- Determination of relative and absolute humidity for extreme air compositions (e.g. boiler house exhaust systems),
- Temperatures up to 300 °C,
- Exhaust gas loaded with particulates and
- Excess and low pressure up to +/- 500 hPa.

Approach

To realize these ambitious objectives, the suitability of various common hygrometric methods for the measuring task was initially analyzed in the first phase of the project. The analysis incorporated the following principles of moisture measurement:

- Capacitive moisture measurement,
- Psychrometric moisture measurement,
- Hygrometric moisture measurement,
- Dielectric material moisture measurement,
- Material moisture measurement based on the principle of conductance and
- Dew point determination with CCC dew point sensors and with a chilled mirror.

Tests were conducted with selected methods to assess their suitability and the limits of potential use. The tests were conducted in a lab with the aid of a climatic cabinet, reference instruments and specially developed test setups. Thus, for example, the principle of the psychrometer was tested in a modified form smaller than common instruments under various conditions.

Another important emphasis of the tests was the moisture sensors' compatibility with pollutants contained in exhaust gases. Figures 1 and 2 plot the effects of intensive pollutant contact on the linearity error of two capacitive moisture sensors of different design. The measured relative moisture rH is mapped to the setpoint rHS. An ideal sensor would lie exactly on the straight red line. Clearly, the deposits of pollutants in its dielectric sustainably influenced sensor type 2. Hence, it cannot be utilized in emission measurement to determine moisture.

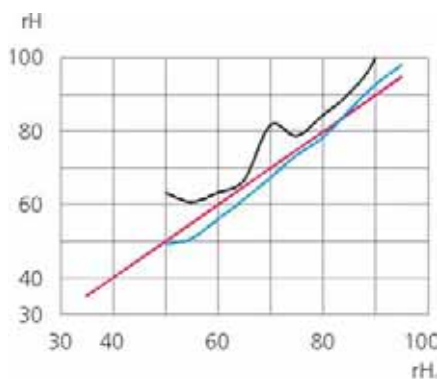

Fig. 1: Linearity error of sensor type 1.

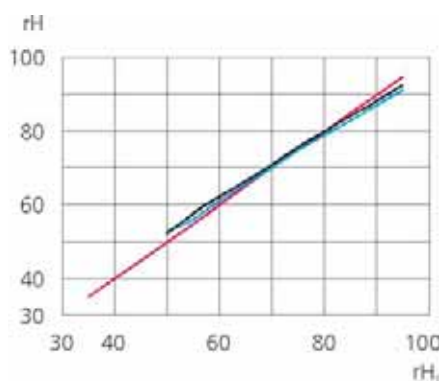

Fig. 2: Linearity error of sensor type 2.

— Setpoint
 — Before exhaust gas contact
 — After exhaust gas contact

The tests conducted served as the basis to develop the concept of the moisture measurement system for emission measurement. Capacitive moisture measurement was selected as the sensor principle. To fulfill all the requirements of emission measurement, the sensor had to be integrated in a compact device that suitably feeds the measuring gas to the sensor. Above all, the pressure differentials had to be overcome, the gas temperature adapted to the sensors' operating range and an isokinetic volumetric flow generated. The complete moisture measurement system consists of the:

- Sampling unit – chimney connector, particulate filter and gas sampling line,
- Basic unit – equalizing module, gas pump, measuring chamber and electronic control and
- Handheld unit – controls, display and memory.

Once the first functional model had been constructed, extensive field tests were conducted. The test results entered into the further development of the moisture measurement system into a device ready for production. The system was evaluated as a whole and technically adjusted from the perspectives of customer utility, measuring accuracy, manufacturer requirements, calibration and maintenance.

Results

The project partners successfully developed a moisture measurement system for emission measurement, which satisfies the stipulated requirements. The system is manageable, able to determine relative and absolute humidity for extreme air compositions (e.g. boiler house exhaust systems) and usable for exhaust gas loaded with particulates at excess and low pressure (500 hPa bis -300 hPa) at temperatures of 300 °C.

The humidity measurement system makes taking emission measurements considerably easier. The measuring point does not have to convert the measured emission values afterward into measured moisture values in the exhaust gas. Normally, this is necessary because the moisture values in the exhaust gas are generally ascertained with molecular sieves and can only be evaluated in a lab.

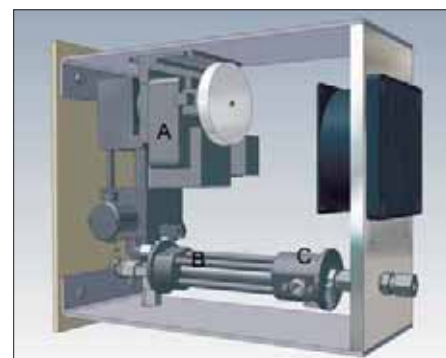

Fig. 3: The moisture measurement system's fluidic components: (A) Gas pump; (B) Equalizing module for pressure, flow and temperature; (C) Measuring chamber.



Fig. 4: Basic moisture measurement system unit for emission measurement.

Moreover, the moisture measurement system provides an option to perform conversions required for input into the emission meter directly in the handheld unit with the aid of algorithms stored in it.

Project Partner

- öko-control GmbH Schönebeck



Automatic Laser Heat-sealing of Large Film Elements

Tino Müller
Tel. +49 391/40 90-241
Tino.Mueller@iff.fraunhofer.de

Silvio Sperling
Tel. +49 391/40 90-232
Silvio.Sperling@iff.fraunhofer.de

Dirk Berndt
Tel. +49 391/40 90-224
Dirk.Berndt@iff.fraunhofer.de

Motivation

Films made of ETFE (ethylene tetrafluoroethylene) are increasingly being used to manufacture special constructions, e.g. roofs, facades and coverings. Individual elements of such constructions consist of inflated film membrane cushions, each of which is mounted in a frame. To manufacture these cushions, individual sheets of film are cut and heat sealed into a three-dimensional shape based on CAD data.

The heat-sealing method currently employed is based on direct heat input with a sealing bar. Its disadvantage is its limited capability to produce curved seals. This method quickly reaches its limits when smaller radii of surface joints are processed.

Therefore, a novel, laser method that facilitates the processing of transparent films is to be used to produce these seams. A laser heat sealing head in conjunction with a suitable film handling system allows processing a far larger range of different seam geometries. As part of the research project described here, the Fraunhofer IFF in collaboration with its project partners is developing methodological approaches, conducting feasibility studies and formulating a concept for an innovative overall system.

Approach

Producing three-dimensional surface seams with laser heat-sealing makes great demands on a system for automatic film handling. During the heat-sealing process, the laser head must move at a constant speed along a nominal contour relative to the film sheeting being heat sealed. The spatial characteristics of the foil elements being manufactured necessitate factoring in every geometric degree of freedom. In addition, the laser's distance to the edge of the film always has to be maintained and a constant overlap width ensured.

A simulation analyzed the challenge of precisely positioning two sheets of film. It was assumed that one film overlay adjusts to the seam's later three-dimensional shape. Varying different parameters, e.g. overlay radius, film edge radii and the films' setting angles, enabled ascertaining the accuracies achievable within one segment of a seam.

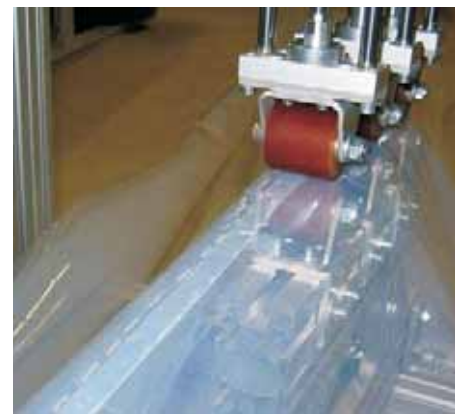

Fig. 1: Film handling test.
Photo: Tino Müller

The project Auto Laser is being supported by the Investitionsbank Sachsen-Anhalt as part of the state of Saxony-Anhalt's innovation policy. (Reference No.: 0604/00059).

Several options for handling the meter-long sheets of film were examined and their practicability evaluated (Fig. 1). The optimal solution is a system that uses special rollers to guide the films past the laser head (Fig. 2). Each roller is provided a separate drive so that the film feed is precisely controlled. In addition, the rollers can be positioned vertically to adjust to the seam. The handling unit is integrated in a travel system that moves linearly along the film support table. An appropriate lab system was implemented to study the feasibility of guiding the film with the roller system.

Three systems have been designed to monitor the heat sealing process.

The first system scans the correct position of the film edges before the laser head with an optical sensor, checks the width of overlap and detects errors in film handling.

The second measurement system integrated in the laser head continually monitors the temperature of the points of heat sealing, which significantly influence the attainable seam quality.

The third system monitors seam quality after heat sealing.

A series of tests analyzed different methods to optically capture the films. The tests were conducted incorporating different light sources, film thicknesses, base properties and seam types and evaluated with imaging methods (Fig. 3).

Results

Extensive preliminary tests demonstrated the feasibility for the different problems. It was possible to develop methods that can be transferred to an overall system. The concept for an overall system was

formulated. This concept is intended to serve as the basis for producing a prototype system to laser heat-seal films in a follow-up project.

Partners

- Halle Branch of the Fraunhofer Institute for Mechanics of Materials IWMH
- KFM Konfektionierung für Membranen GmbH Wallhausen

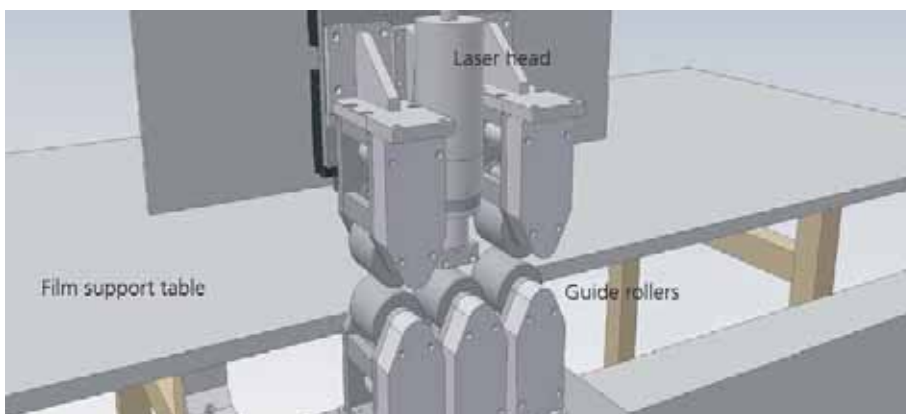

Fig. 2: CAD model of the heat-sealing system (prototype).

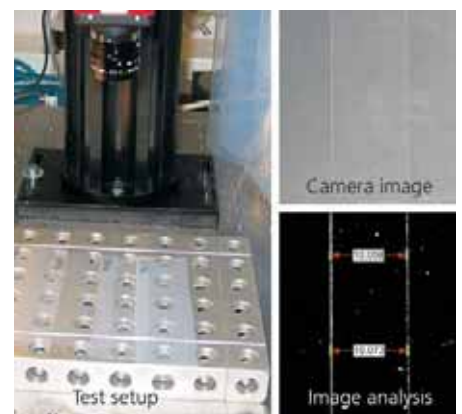

Fig. 3: Evaluation of the width of overlap. Photo: Tino Müller

Project Reports from the
Logistics and Factory Systems Business Unit

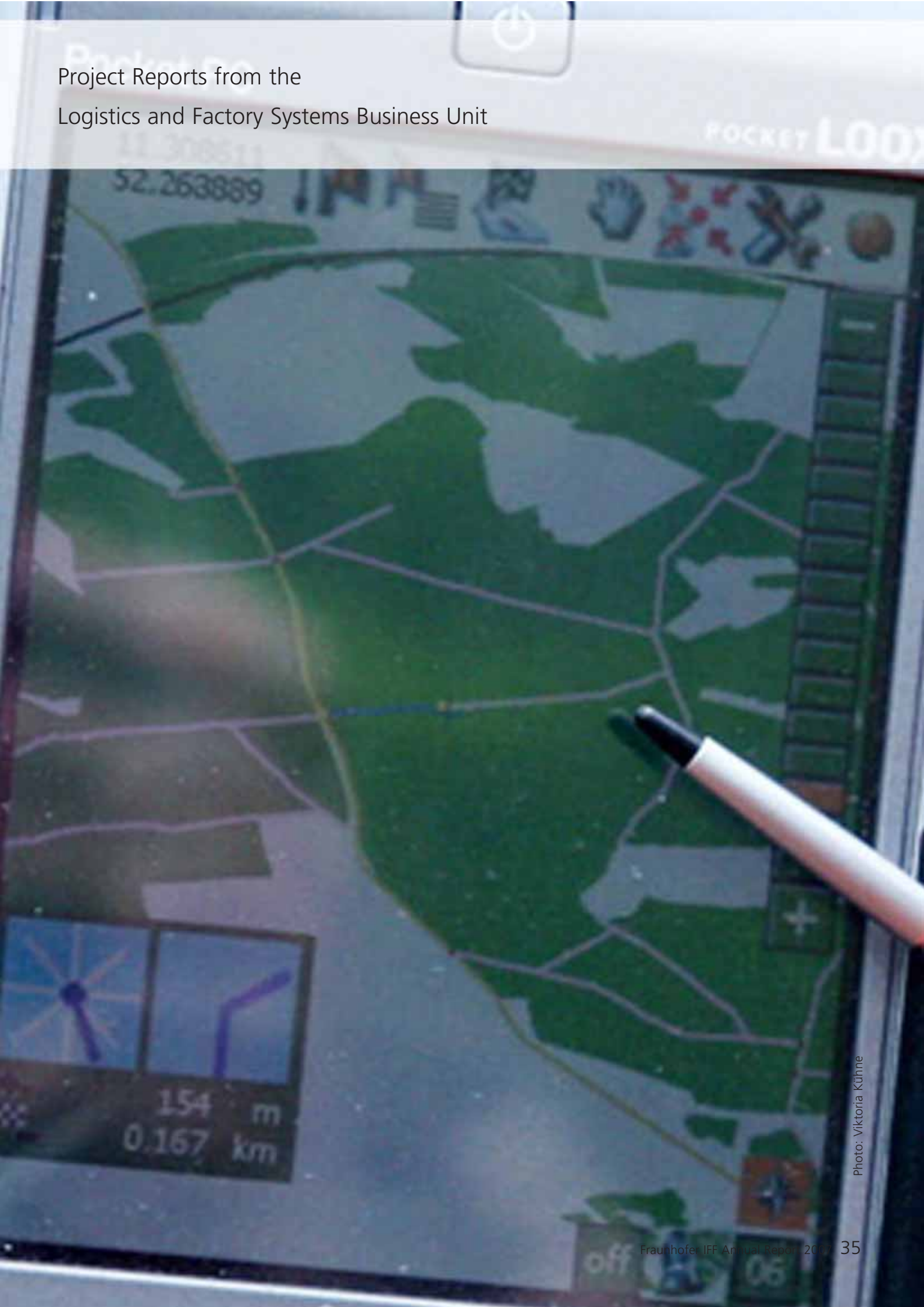

Photo: Viktoria Kühne

Rolf Walter
Tel. + 49 391/40 90-139
Rolf.Walter@iff.fraunhofer.de

Jörg von Garrel
Tel. + 49 391/40 90-714
Joerg.Garrel@iff.fraunhofer.de

Daniel Reh
Tel. + 49 391/40 90-143
Daniel.Reh@iff.fraunhofer.de

Initial Situation

Mounting customer needs, globalizing markets and growing quality requirements are causing innovation cycles in research and business sectors to shorten. Handling this complexity necessitates the increased use of specialized resources.

While large concerns are able to specifically assign entire units or contract external organizations for this purpose, small and medium-sized enterprises hardly have any options to take part in and profit from market trends. While they have numerous innovative ideas for product and technology developments, a variety of factors prevent their prompt development.

In this context, cooperation and networks present small and medium-sized enterprises an excellent opportunity to systematically develop innovations, i.e. new or noticeably improved products and services, despite their limited resources.

Just how systematically do innovation activities proceed in corporate practice and what are the dominant drivers and obstacles? What methods and instruments are practical for small and medium-sized enterprises to standardize and optimize their innovation activities?

Approach

To answer these and other questions, the Fraunhofer IFF conducted an online survey from September through October 2007. The survey consisted of six thematic areas:

- General corporate data,
- Innovation performance,
- Influencing factors,
- Innovation process,
- Integrative innovation process and
- Methods of the innovation process.

A total of seventy-eight companies responded, which, in terms of size, industry affiliation and regional distribution, basically conformed with the industry as a whole:

Expanding on previous studies, this company survey concentrated both on the application of systematic and integrative innovation processes and the methods utilized in the innovation process in companies and bundled these aspects into one holistic view.

This survey was conducted as part of the project MOSIS: Development and Field Implementation of a Methodology Kit Suitable for SME to Optimize and Standardize Corporate and Integrative Innovation Processes supported by the Stiftung Industrieforschung (Reference No.: S 801).

Results

The evaluation of the survey yielded an overview of the corporate situation:

- The majority of the respondent small and medium-sized enterprises have scant systematic innovation processes. Innovation processes executed according to a system predominate in 38 percent.
- In particular, the implementation phase, i.e. establishing an innovation on the market, presents the greatest challenge to companies in their innovation processes.
- The analysis of the scope and intensity of cooperation yielded the lowest values from companies (the scope of cooperation actually being the lowest value) in this phase. Entering strategic cooperations to build up a greater level of confidence and thus effective implementation on the market appears to be helpful to small and medium-sized enterprises precisely in this phase.

- Respondent companies apply few methods and instruments to standardize and optimize their innovation process.

The use of methods that require substantial time and labor ties up a large share of a company's overall capacity and thus directly conflicts with the transaction of day-to-day business. Paradoxically, resource conservation is one of the fundamental effects whenever such methods are applied, e.g. time savings by preventing misguided developments. Naturally, the implementation of a method initially requires time and effort. The delay usual before the benefits from applying a method can be recognized appears to engender an inadequate grasp of problems/benefits in companies.



Fig.: Scope of the use of methods and elimination criteria.

Recommendions for Action

The following actions need to be taken to guarantee practical knowledge is inferred and thus to increase small and medium-sized enterprises' innovation potential

1. A standardized corporate and integrative innovation process must be established as a template and orientation aid for small and medium-sized enterprises and their networks (i.e. as a standard project workflow for innovation processes).
2. An easily manageable instrument suitable for the analysis of corporate and integrative innovation processes must be created to enable small and medium-sized enterprises to independently identify fields for action and weak points in the innovation process specific to their company so they can continuously optimize their processes.
3. The multitude of existing methods must be made more readily explorable by small and medium-sized enterprises. To this end, they must be simplified substantially, augmented with aids and model applications and made accessible.

Project Partners

The project is being implemented in cooperation with the Bildungswerk der Wirtschaft Sachsen-Anhalt e.V.

For information on the small and medium-sized enterprises involved as well as general information visit www.projekt-mosis.de.

Fifteen Small and Medium-sized Enterprises on the Road to Knowledge Management

Stefan Voigt
Tel. +49 391/40 90-713
Stefan.Voigt@iff.fraunhofer.de

Motivation

Independently implementing knowledge management and the related objectives of sustainably improving the handling of knowledge has become existential for enterprises. The project "ProWis: Process-oriented and Integrated Knowledge Management in SME" is tackling this challenge by systematizing and comprehensibly processing numerous aids for the analysis, engineering and implementation of knowledge management solutions.

Approach

In a first step, fifteen small and medium-sized enterprises from the automotive supplier, machinery manufacturing and electronics industry were analyzed. An online employee survey identified the status quo of the need for/availability of knowledge, the handling (generation, storage, distribution and application) of knowledge and the constraints (e.g. management and culture). Afterward, the handling of knowledge in each of the business processes focused on was qualitatively analyzed in group interviews. The results yielded a detailed picture of deficits in the handling of corporate knowledge critical to success.

Once the results of the analysis are available, the ProWis approach model calls for the formation of internal company teams that prioritize the fields of action and accordingly define the objectives. The employees' ideas on developing the potentials are collected at a concept workshop and augmented with potential management solutions from the ProWis Shop.

Developed in the course of the project, the ProWis-Shop is an Internet platform available to companies as a sound source of information on the implementation of knowledge management. A key feature is the solution box that, taking knowledge management solutions as its starting point, systematizes selection criteria pertinent for small and medium-sized enterprises. This ensures proper solutions are independently selected after the analysis. In addition, it is possible to enter into contact and actively and practically exchange experience with enterprises already working on practical implementation. In conclusion, the independently selected solutions are finally adapted to an enterprises specific needs and their implementation is planned.

Results

A key result of the analysis of the fifteen enterprises is the increasing importance of knowledge about small and medium-sized enterprises' external environment (customers, markets and competitors). The need for related information continuously revealed a great discrepancy between the perceived relevance and the availability of these knowledge contents (see Figure). Thus, closing the knowledge gaps constitutes a key challenge in order to be able to respond to those changes in the corporate environment (e.g. mounting competitive pressure, internationalization) in the future too.

ProWis is being supported by the Federal Ministry of Economics and Technology BMWi. (Reference No.: VII B 4-00 30 70/4)



Fig.: Key knowledge domains with reference to relevance and internal availability.

Moreover, knowledge about a company's specific products and services and employees' technical and methodological knowledge turned out to constitute the most important "internal" fields of knowledge. These are based on an extremely large amount of know-how that constitutes a key success factor to handle the tasks of daily work.

Thus, knowledge specific to a company is strongly tied to individuals. This knowledge proved to be available in part only to a limited extent in the enterprises analyzed. Thus, the systematic and more thorough documentation of (know-how

and) knowledge specific to a company constitutes another general challenge for small and medium-sized enterprises. (The detailed evaluation is summarized in a study on www.prowis.net.)

The implementation of so-called Wikis proved to be the most suitable solution for the participating enterprises. Wikis are authoring systems with which contents of websites can be easily edited. The best known Wiki is www.wikipedia.org, the software for which is available as a free download.

Another reason for the great interest in Wiki technology is the virtually democratic philosophy on which it is based. Any user may enter contents and further develop contents from other users. This simple procedure generates high quality, up-to-date texts after a few iterative loops. Apart from the intuitive handling, the installation executable with little effort also speaks for the system. On the one hand, a Wiki places a highly up-to-date information source at enterprises' disposal and, on the other hand, it fosters the development of networks of employees interested in similar fields.

Not only such technical knowledge management solutions but also methods geared more toward organization, e.g. workshops to secure experience from projects and the structuring of meetings for the fifteen small and medium-sized enterprises, were very popular too. An overview of over fifty knowledge management solutions can be found at <http://shop.prowis.net>. Interested enterprises may set up a free user account.

Project Partners

- Fraunhofer Institute for Production Systems and Design Technology IPK
- Information on the 15 small and medium-sized enterprises involved is accessible on www.prowis.net

World Class Launch 2020: Around the World in Sixty-six Days - A Paradigm Change in the Automotive Industry

Holger Seidel
 Tel. + 49 391/40 90-123
 Holger.Seidel@iff.fraunhofer.de

Rolf Walter
 Tel. + 49 391/40 90-139
 Rolf.Walter@iff.fraunhofer.de

Initial Situation

Without a doubt, the automotive industry continues to constitute one of the German economy's most important sectors. Yet, the familiar effects of globalization are compelling companies to do some rethinking in order to be able to handle dynamic market conditions and customer demands. This situation makes an analysis of Germany's automotive regions and, in particular, the eastern German automotive industry, which has experienced dramatic change and restructuring in the last twenty years since reunification, interesting. Global developments give rise to the question whether the newly established structures in eastern Germany are up to the challenges and what future requirements it will have to deal with.

In its incipency last century, motor vehicle production was already dispersed throughout several regions throughout Germany. This structure was largely retained even when Germany was divided after the Second World War. In particular, the region around Zwickau and Chemnitz became a major automotive center in the GDR.

Since their low productivity could not even satisfy domestic demand, East German manufacturers chiefly produced for the domestic market while Germany was divided. The East German automotive industry collapsed after reunification. One of the first globally operating vehicle manufacturers (OEM), Volkswagen AG located in the Zwickau-Chemnitz region, which had been a home to qualified skilled labor with extensive know-how since the start of automobile production. Other vehicle manufacturers followed. Another automotive region was created when Porsche and BMW located in Leipzig. In addition to these facilities, regional supplier structures also arose, thus reinforcing the positive effect the

establishment of these facilities had for Central Germany.

In recent years, regional networks have been created and then merged into state initiatives to establish effective collaboration between manufacturers. The Eastern German Automotive Cluster ACOD was, in turn, founded in 2004 to intensify the individual clusters' collaboration. ACOD aims to sustainably boost the interstate automotive industry in eastern Germany by bundling regional activities and generating synergies in the sector. This has given rise to a joint action platform for OEM, suppliers, service providers, research organizations, industry associations and other institutions in the five eastern states. ACOD will also be confronting future developments a study was intended to identify.

The automotive sector is generally subject to a constantly evolving dynamic in terms of market changes and new technology developments. Hence, the time from the development up through the final manufacturing of new and innovative products compared to the competition is steadily growing in importance. Thus, product development is evolving into a decisive

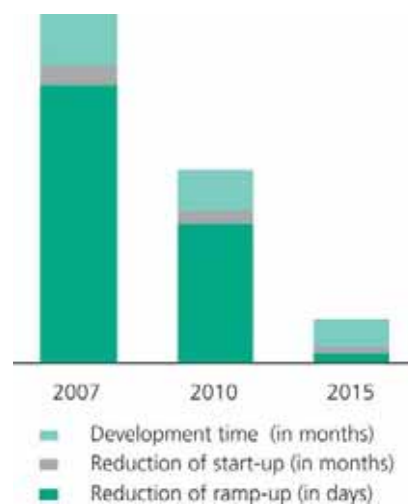

Fig. 1: Structural changes in the product development process over time.

competitive factor for the entire automotive sector (Fig. 1). The effects of this change have not yet been defined as best practice solutions.

Only the fewest vehicle manufacturers currently possess comprehensive and cross-company knowledge of the strategies, processes and methods necessary to perform excellently throughout the entire value added chain. Moreover, information grounded in research on best practices to start-up, ramp-up and launch a product in the automotive sector does not yet exist. This information gap was the motive to conduct the global automotive study "World Class Launch".

Results

Defining the study's goals entailed identifying the most important trends in the automotive industry, the so-called hypertrends (Fig. 2), and the fundamental levers for effective launch management based on best practices for start-up. Another objective of the study was to measure the status of the implementation of manufacturers' current efforts to optimize ramp-up and launch performance. Therefore, a holistic approach to analysis throughout the entire value added chain was selected for the World Class Launch study to demonstrate the necessity for an integrated concept for the launch of new products. This makes excellent start-up, ramp-up and launch services achievable on a long term basis. The outcome of the study made it easy to gauge every analyzed manufacturer's need for action and the current state of development compared with the competition. The results provided a basis to derive operative and strategic management guidelines for carmakers to effectively and efficiently organize product development processes to be able to acquire and secure a competitive edge.

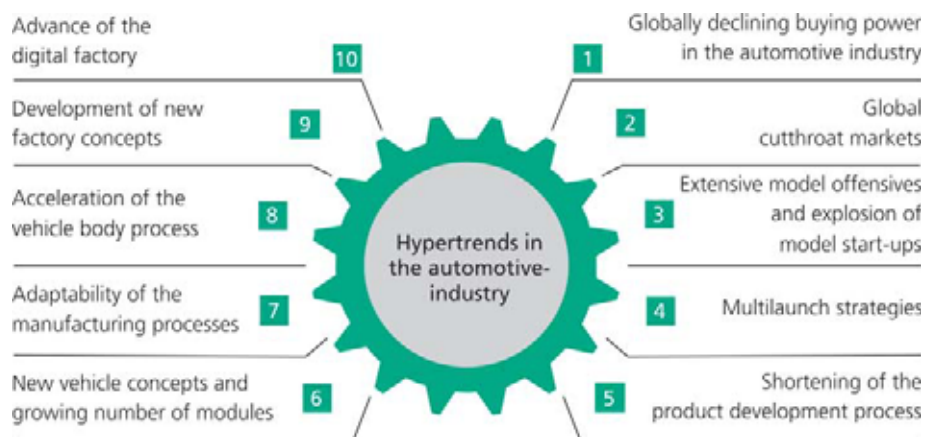

Fig. 2: Hypertrends in the automotive industry.

The hypertrends identified produce new requirements specifically for logistics. Shortening product life cycles, the related rising number of model start-ups and the steadily increasing diversification of vehicles and models necessitate organizing logistics processes flexibly and adaptively. This not only requires the optimization of existing processes but also new logistics concepts and control strategies, which affect the entire value added chain. Given this situation, the synchronization of manufacturing and logistics processes and cost and resource-effective logistics will become important. The high cost pressure acting on carmakers and suppliers throughout the world is compelling them to seek potentials to reduce costs by utilizing new technologies and tools. One essential tool is the digital factory with which logistics processes and control strategies can be virtually planned and simulated in advance of implementation. In addition, this tool can interconnect individual processes so that value added chains can be implemented in their full breadth and depth.

The hypertrends identified and their consequences for logistics must form the basis for further action on the part of ACOD. Only anticipating the developments presented will make it possible to partake in future successes.

Project Partner

- MBtech Consulting GmbH



Interregional Collaboration on Biomass Utilization

Dr. Ina Ehrhardt
Tel. +49 391/40 90-811
Ina.Ehrhardt@iff.fraunhofer.de

Mike Wäsche
Tel. +49 391/40 90-364
Mike.Waesch@iff.fraunhofer.de

Motivation

Global warming is not a local occurrence. It calls for collective international political, scientific and economic action to avert ominous consequences for future generations.

As part of the project "Perspectives 2007-2013", the regions of Saxony-Anhalt in Germany, Valencia in Spain, Eszak-Alföldi in Hungary and Centre in France agreed to implement a joint project. The program is aimed at promoting the regions' collaboration to enhance regional competitiveness and improve sustainability. One emphasis from 2007 to 2008 is the exchange of concepts to improve the utilization of renewable energies with the goal of long-term cooperation.

The Fraunhofer IFF (Saxony-Anhalt), the College of Nyíregyháza (Eszak-Alföldi) and the Chamber of Commerce of Valencia and AIDIMA (Valencia) are interregionally collaborating on the subproject "Interregional Cooperation on Biomass Utilization" to exchange experiences and develop joint action concepts.

Attended by 14,000 students, the College of Nyíregyháza is the second largest academic institution in the region of Eszak-Alföldi. Registered with the Spanish Interministerial Commission for Science and Technology, AIDIMA is a private non-academic research organization specialized in research and development for the wood processing industry.

The Chamber of Commerce of Valencia is one of eighty-four in Spain and specifically provides regional small and medium-sized enterprises services and consulting, e.g. for corporate development, marketing networking.

The European Commission and the State of Saxony-Anhalt are supporting the project "Interregional Cooperation on Biomass Utilization" through 2008 as part of the Interreg IIIC program's project "RFO Perspective 2007-2013".

Approach

At work meetings, the project partners presented their own specializations, their networking with key industry and research players and representative examples of the recovery of material and energy from biomass in their particular regions.

In another step, the partners developed commonalities and differences in the development and state of the utilization of renewable energies in the three regions. The results were compiled in a multilingual brochure entitled "Interregional Cooperation on Biomass Utilization" and distributed in the regions.

Results

Along with differences based in the given infrastructural, geographic, economic and social conditions, the partners collaboratively identified good practices and significant fields to focus actions on the research and development of biomass utilization in the regions involved.

The main foci of logistics and energy conversion technologies are of major importance. Both foci were the center of attention at the interregional forum on the development and utilization of biomass hosted by the partners in Nyíregyháza (Eszak-Alföldi,) on September 20 and 21, 2007. The forum was attended by over eighty practitioners from agroforestry and biomass material and energy processing industry, political and governmental policymakers and representatives from academia and research. Speakers from the regions involved not only presented the attendees from six countries approaches and

efforts in the region of Eszak-Alföldi but also current results from research and development and innovative technologies and practical applications from the regions of Saxony-Anhalt and Valencia to sustainably utilize biomass, factoring in influencing ecological and economic factors.

The cooperation begun in the project, the key players identified and brought together and the interregional partner network present unique opportunities to jointly continue this work in future projects. One example of the efforts to take advantage of these opportunities is another project on improving the utilization of biomass in the regions already jointly initiated by the project partners as part of the 7th Research Framework Programme.



Fig. 1: The energy source of the future – timber harvesting in a forest. Photo: Mike Wäsche

Project Partners

- Chamber of Commerce of Valencia (Spain)
- AIDIMA (Spain)
- College of Nyíregyháza (Hungary)



Fig. 2: Further processing of harvested timber into woodchips. Photo: Ina Ehrhardt



Condition Monitoring of Components of Wind Energy Converter Drive Trains

Frank Ryll
Tel. +49 391/40 90-413
Frank.Ryll@iff.fraunhofer.de

Motivation

The contribution of future offshore wind parks off the German coast of the Baltic and North Seas to the supply of energy from renewable sources and their economic success essentially depends on the reliability of the wind energy converters utilized.

Unlike other energy conversion plants, wind energy converters are characterized by a transient mode of operation. The wind's variability causes many stochastic load fractions. This distinctive feature must be factored in when engineering wind energy converter components and when implementing maintenance strategies

The objective of this R&D project was to measure the varying loads during operation and evaluate their impact on the depletion of drive train components' (main shaft, shaft bearing, gear unit) reserves of wear. This can be built upon to develop quality, operating and maintenance strategies so that the technical availability of the converters increases and maintenance work can be performed based on condition at a defined time and as a function of meteorological, logistical and energy management parameters.

Conceptual Solution

The loads of a wind energy converter's drive train components greatly depend on the rate and dynamic of the transmitted torque. A measuring system must satisfy the requirements of the measurement task as large diameter shafts rotate slowly and factor in the special operating conditions of wind energy converters. Moreover, financial restriction have to be taken into account.

Every principle of torque measurement is based on measuring the shaft's revolution by applying force. Research revealed that the current method of choice is measurement of shaft torsion by means of strain gauges without engaging the drive shaft. Other methods are still too costly at present and/or cannot be employed under the harsh operating conditions. In addition, structural changes to the shaft are frequently necessary. This diminishes its stressability and makes its retrofitability difficult. Strain gauges utilize the simple physical principle of the dependence of an electric conductor's resistance on its cross section. To measure torque, a total of four strain gauges are applied to an accessible section of the shaft in the direction of the principal stress. Fig. 1 shows their installation in a

The project "DEIKE: Measurement of Speed of Transient Collective Load Events" was supported until 2006. by BIS Bremerhavener Gesellschaft für Investitionsförderung und Stadtentwicklung mbH with funds from the State of Bremen and the EU as part of its Program to Promote Applied Environmental Technologies PFAU.
(Reference No.: 51031-A)



Fig. 1: Measurement of torque, speed and angle of rotation on a wind energy converter's main shaft.
Photo: Frank Ryll

test converter together with a measuring system developed at the Fraunhofer IFF that determines speed and angle of rotation on the basis of RFID transponders and a telemetry unit that wirelessly transmits measured values from the rotating shaft to an analysis PC in the base of the wind energy converter tower.

Evaluation is based on real-time detection of typical operating situations (load cases) of wind energy converters, which stress their components differently. To this end, an evaluation model based on an artificial neural network (ANN) was designed as a learning vector quantization network (LVQ) and tested. Input data are torque and rotor speed, position and acceleration. A total of sixteen normal and fault load cases identifiable through implicit patterns in the training data were defined for classification. For every load case identified, a fuzzy evaluation system determines components' stress in context with other operating and condition parameters and maintenance work performed. This can be used to infer consumption of the reserve of wear and, from this, the current reserve of wear and the probable remaining useful life (Fig. 2).

Benefits

The methods described were integrated in a condition monitoring system with the following benefits for converter operators, maintenance providers and insurers:

- Cost effective online evaluation of current and anticipated condition in ongoing operation utilizing measured data and experiential knowledge,

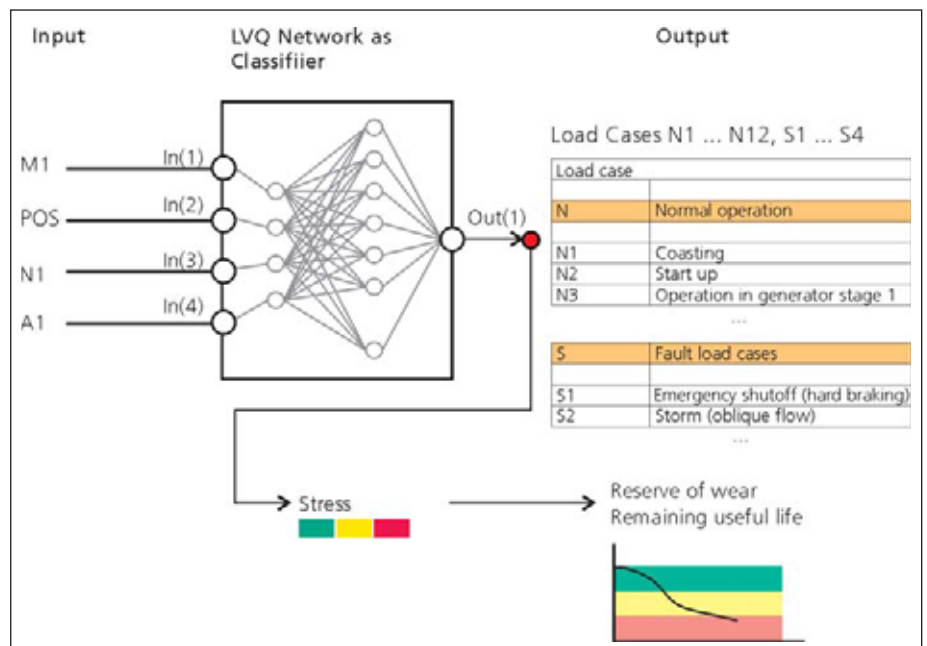

Fig. 2: Evaluation method based on an artificial neural network.

- Inferences for further converter operation and condition-based maintenance,
- Reduced risk of failure by continuously monitoring complex correlations,
- Guaranteed return through higher technical availability,
- A basis for resource planning, LCC and TCO approaches,
- Maintenance history file on stresses and maintenance measures and
- Acquisition and retention of converter know-how as a storage system of experiences with the operation of converters and the organization of service partnerships.

Outlook

The Fraunhofer IFF Logistics and Factory Systems Business Unit's Maintenance and Service Management Group is incorporating the results of the project into the strategic development of its Stateloger®.

Project Partners

- meteocontrol GmbH, Bremerhaven Branch
- Dieter Bosch Maintenance Engineering, Bremerhaven



Transferring European Best Practices to Promote Sustainable Management in Thai and Vietnamese Enterprises

Ralf Opierzynski
Tel. +49 391/40 90-352
Ralf.Opierzynski@iff.fraunhofer.de

Motivation

Over 90 percent of the established companies in Southeast Asia are classified as small and medium-sized enterprises (SME). They are deeply rooted in the societies in which they operate, providing income and supplying essential products and services to a majority of the population.

The influence of small and medium-sized enterprises is also reflected in other domains. A sizeable share of the economic output in Southeast Asia's national economies is produced by SME. They are an integral part of global value added chains and greatly influence the economic performance of large enterprises and multinational concerns.

Moreover, national and international environmental initiatives e.g. on global warming, are difficult to implement without integrating SME. While their individual influence on total emissions and resource consumption is negligible, small and medium-sized enterprises have accumulated far more significant influence than large enterprises for instance. What is more, they hold far more potential for improvement with respect to more resource-efficient manufacturing than large enterprises and multinational concerns.

Small and medium-sized enterprises are therefore extremely important for sustainable national economic development.

Approach

Small and medium-sized enterprises significantly influence all three dimensions of a sustainability analysis: The environment, the economy and society. This is the point of departure for the project Empowering Asian Business Intermediaries through Knowledge-based Networking Focused on Sustainability Management EMPASIA initiated by the Fraunhofer IFF.

Together with its partners from the Louth County Enterprise Board (LCEB) in Ireland, the Asian Society for Environmental Protection (ASEP) in Thailand and the Vietnam Productivity Center (VPC) in Vietnam, the Fraunhofer IFF developed qualification actions for local multipliers in Thailand and Vietnam, particularly focused on sustainability management for SME.

The project's work packages included:

- Establishing an international partner network,
- Qualifying the partners in sustainability management and corporate social responsibility (CSR) and
- Establishing a PLATO® network to sustainably support Asian SME.

The transnational network created by the project consists of partners from academia and research as well as industry. Both north-south exchange between Europe and Asia and south-south exchange in Asia are priorities in the network. The target group of multipliers in the project includes industry associations, non-governmental organizations, universities and chambers of commerce.

The project "EMPASIA" is being supported by the European Commission until 2009 as part of the EuropeAid Asia Invest II program.
(Reference No.: TH/Asia Invest/06 (139-447))



Fig.: Attendees from fifteen Bangkok organizations and companies at the first meeting of the EMPASIA Advisory Board in Bangkok on February 5, 2008. Photo: Ralf Opierszynski

For instance, the SME Bank, the National Science and Technology Development Agency (NSTDA), the National Food Institute (NFI), the Office of Small and Medium Enterprises Promotion (OSMEP) and Thailand Textile Institute (THTI) were recruited in Thailand to actively participate in the EMPASIA project.

The METRO Group Vietnam, Ford Vietnam Ltd., the Co-operative Union Hai Phong and the Vietnam Commercial University agreed to support the project in Vietnam.

These organizations are actively integrated as stakeholders in the projects' National Advisory Boards and thus facilitate ongoing dialog between business, research and government. The networks of enterprises and governmental and non-governmental organizations the Fraunhofer IFF has established through

its activities in Southeast Asia since 1999 were crucial to recruiting the organizations collaborating on the project.

The network qualifies the Asian partners to qualify enterprises in sustainability management and CSR using innovative tools of IT based knowledge management.

Building upon these qualification actions, workshops on corporate sustainability management and CSR specifically tailored to the needs of SME will follow. The Fraunhofer IFF is able to draw on years of experience in this field in Southeast Asia.

Thus, the EMPASIA project is in accord with both national and international initiatives, e.g. Thailand's national development plan and the UN Decade of Education for Sustainable Development.

In addition, the project is transferring PLATO® , one of the most effective European approaches to promote SME, to expand the local partners' service portfolios and improve support for SME in Thailand and Vietnam.

The two-year EMPASIA project will implement a total of two PLATO® pilot regions in Bangkok and Hanoi. The outcome will be the initiation of regional and national dissemination.

Outlook

In the upcoming phases of the project, the project consortium will concentrate on expanding the SME network and multiplier network as well as the international partner network.

This is an open partner network. Thus, interested enterprises and organizations can directly or indirectly participate in the project as partners and support the European-Asian exchange between multipliers. Consequently, the partner network constitutes an excellent platform to initiate and developing research cooperation and initiating concrete business transactions. Interested enterprises and organizations should contact the project coordinator at the Fraunhofer IFF directly.

Visit www.empasia.org for more information on the content of the project, its progress and events.

Project Reports from the
Material Handling Engineering and Systems Expert Group



Photo: Woody Stein

Innovative Technologies and Their Demonstration for Localization in Buildings

Dr. Klaus Richter
Tel. +49 391/40 90-420
Klaus.Richter@iff.fraunhofer.de

Motivation

GNSS-INDOOR is intensively researching, testing and demonstrating various technologies for localization and navigation in different types of buildings and their immediate vicinity. The focus is concentrated on different system architectures for diverse logistics and security applications. The various localization technologies will not only be tested at the Fraunhofer IFF Magdeburg's LogMotionLab but also implemented and then field tested at Leipzig/Halle Airport. GNSS-INDOOR is working with localization technologies employing:

- A-GPS (Assisted Global Positioning System),
- GSM (Global System for Mobile Communications),
- WLAN (wireless local area network),
- RFID (radio frequency identification),
- Ultrasound and
- Map matching.

Focus on Combined Use

A localization system alone is insufficient for many logistics applications since different domains must often be covered, e.g. transport routes, plant premises and warehouses. The combined use of various technologies makes sense wherever isolated systems reach their limits. GNSS-INDOOR is paying particular attention to this aspect. Once technologies and user requirements have been surveyed, a preliminary selection will be made. Localization systems not suited for GNSS-INDOOR will be eliminated. The localization technologies selected will be tested and analyzed in-depth. Concepts for the combined utilization and integration of selected individual systems will be formulated from the data obtained and requirements and typical operating conditions for the different applications factored in.



The project GNSS-INDOOR is being supported by the German Aerospace Center (DLR) with funds from the Federal Ministry of Economics and Technology. (Reference No.: 50 NA 0701)

Fig. 1: Cargo handling on an airport's ramp.
Photo: © Jettainer GmbH/Lufthansa Cargo AG

Fields of Application

There are a multitude of domains for GNSS-INDOOR applications, including:

- Emergency calls with position data (E 112),
- Localization of vehicles in tunnels,
- Secure chains of goods,
- Pedestrian flows in public buildings,
- Surveillance,
- Event logistics,
- Luggage cart management,
- Construction site logistics,
- Electronic museum guide and
- Trade show, airport, harbor and train station navigation.

While the emphasis is on the domains of logistics and security applications, some of the applications will also be usable to develop new markets.

Exploitation of the Results

Mainly small and medium-sized enterprises are involved in GNSS-INDOOR. They are instrumental in speedily turning the research findings obtained into innovative products and services and positioning them on the market. The early involvement of potential customers also supports purposeful development and will accelerate any future market launch. The project partners will use the concept formulated to collectively or individually produce newly developed products and services. GNSS-INDOOR will contribute to safeguarding highly qualified jobs in growth markets. At the same time, the project work is creating new jobs in the key technologies of satellite navigation, mobile communications, RFID, logistic and security.

Project Partners

- VEGA IT GmbH
- OECON GmbH
- Centre for Satellite Navigation in Hesse
- Scheller Systemtechnik GmbH
- Friedrich Schiller University Jena

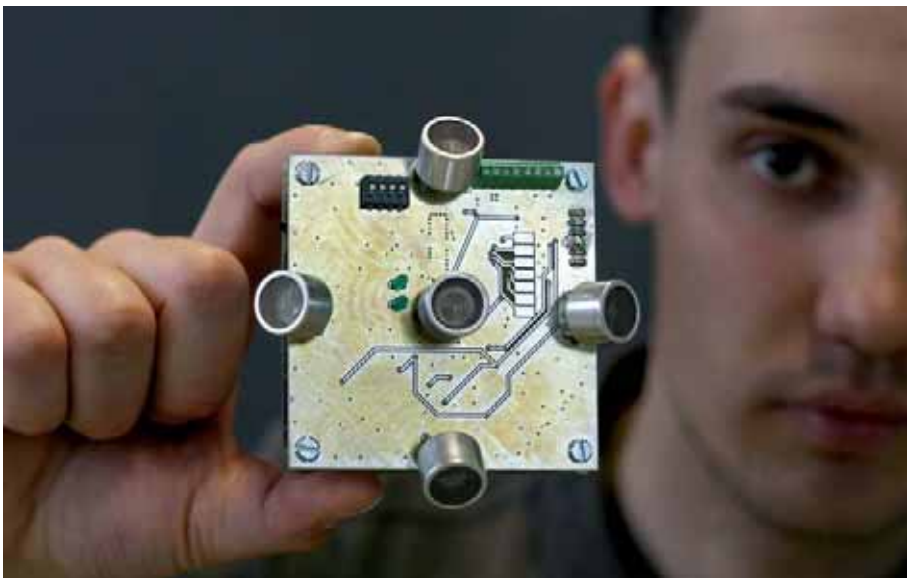

Fig. 2: Mobile ultrasonic position finding device.
Photo: Dirk Mahler



SACHSEN-ANHALT

Radio-based Interaction Analysis to Evaluate Pedestrian Flows

Dr. Klaus Richter
Tel. +49 391/40 90-420
Klaus.Richter@iff.fraunhofer.de

Bernd Gebert
Tel. +49 391/40 90-412
Bernd.Gebert@iff.fraunhofer.de

Stefan Miot
Tel. +49 391/40 90-163
Stefan.Miot@iff.fraunhofer.de

Motivation

Information the location of individuals or objects in the context of time is a useful basic attribute to evaluate their interactions and their current status in a process. The automatic capture and processing of position data promises to make new control and evaluation concepts possible in many fields of application.

In sports, athletes routinely use position data to analyze performance and competition. An individual athlete's level of performance is observed or the interaction of several individuals is analyzed to derive appropriate training measures or check their effect. State-of-the-art localization systems based on radio frequency (RF) technology furnish new options to precisely determine the position of objects in near real time. They promise to be easy to use under standard conditions and adaptable to diverse application scenarios and environmental conditions.

Difficult conditions and thus limits on the use of available RF systems arise when the objects to be localized are moving at high speed or cause shadowing of the radio antennas. Furthermore, water, metal or other materials located in the radio field can cause damping and reflection that influence the function of RF localization equipment. High requirements are placed on RF localization systems when high accuracy or a high scanning rate of the captured position is required.

Present systems for athletic performance diagnostics operate with special markers applied to athletes and the analysis of recorded video data. Since it has not yet been possible to fully automate the analysis of video material, analysis still demands a great amount of manual labor despite great advances in automatic marker tracking. The analysis of a handball game requires around twenty-four hours.¹ A single individual must work some twenty hours on an analysis to obtain the results from a three minute team competition composition in rhythmic gymnastics. The interaction between different athletes hardly receives attention and is still a largely unresearched field.

Approach

As part of the collaborative project RF@Sports supported by the Investitionsbank Sachsen-Anhalt, a prototype RF real-time compatible analysis systems was designed, constructed and tested together with the partner Siemens AG. The system automatically analyzes the movements and interactions of individuals in sports under real conditions and in real time and in postprocessing. Once a suitable localization system had been selected and commissioned, an extensible tool to record and analyze motion data was designed in the RF@Sports project. The experiences of practicing coaches entered into the requirements specification for the software.

The system built as a prototype under reference conditions with > 0.05 meters and 1,000 hertz attains the positioning accuracies and scanning rates (< 0.25 meters, 200 hertz) determined to be relevant for athletic performance diagnostics.

The project RF@Sports was supported by the Investitionsbank Sachsen-Anhalt.

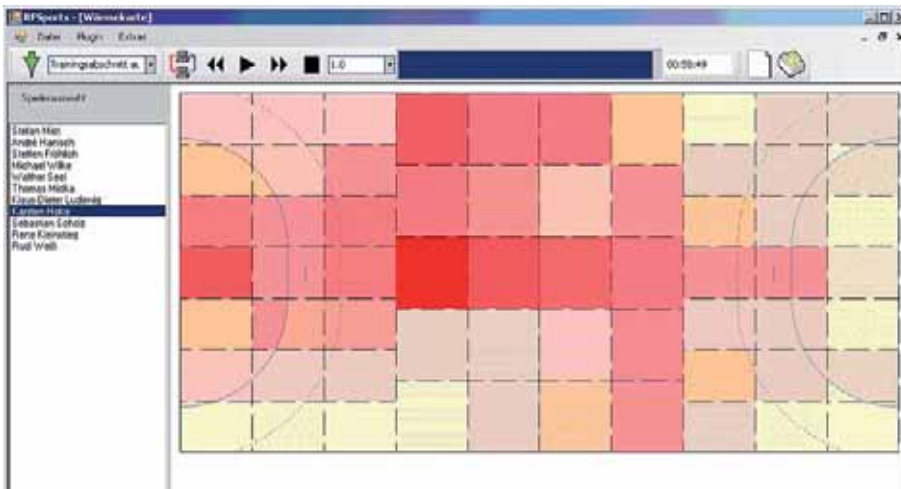

Fig. 1: Heat map with RF@Sports software. The intensity of red in a sector indicates an individual's relative residence time there.

Results

RF@Sports software was initially geared toward planning and controlling handball players and rhythmic gymnasts' training but can also be adapted to other fields of application. Analyses such as the heat map of the cumulative residence frequency in the individual sections of the discretely divided sector of localization over time are universally valid and also useable in fields of application outside athletics (Fig. 1). The corresponding section of the sector of localization takes on a more intensely red color as the relative residence time increases.

The RF@Sports system was used to support training of junior teams and rated by coaches as beneficial and applicable. The larger quantity of objects observed in parallel and automatically than in conventional systems received a particularly positive assessment.

The range of analyses possible with the software prototype already exceeds the range of functions of comparable athletic performance diagnostic systems. In terms of its structural design including steel girders and an outer shell with sheet metal siding and its dimensions, the hall environment selected for the implementation of the prototype represents a typical site of use corresponding to the requirements for the targeted uses in sports and event logistics. Currently available RF based localization systems reach the limits of their performance here because of the poor conditions for wireless technology. This constitutes a challenge to be overcome in practice.

The proven applicability of the systems demonstrates that beneficial localization applications can be created even in critical environments. Providing position data in real time opens previously unused potentials for analysis.

The system has also been implemented in a ski hall in the meantime.

Project Partner

– Siemens AG



Fig. 2: Preparing a downhill skier to capture his activity.
Photo: Dirk Mahler

¹ Kall, T.O.: Profis in der digitalen Welt; Handball Magazin 5/2004

Dr. Klaus Richter
Tel. +49 (0) 391/40 90-420
Klaus.Richter@iff.fraunhofer.de

Corinna Kunert
Tel. +49 (0) 391/40 90-620
Corinna.Kunert@iff.fraunhofer.de

Cleverly through Downtown with Interchangeable Trailers

Motivation

The customer is king - a fact that is especially confronting logisticians with ever greater challenges. Increased customer demands regarding delivery time, punctuality and delivery close to the place of consumption have generated an enormous rise in delivery traffic, above all in urban areas. Given the large share of empty runs in regional commercial traffic, organizing commercial traffic to be cost effective has to go hand in hand with organizing it to be environmentally compatible with urban development. Organizing commercial traffic to be environmentally compatible with urban development is not only an extremely important issue in Europe but also a fundamental task for logistics research on federal and state levels.

The research project "Best4City: Low Volume Commercial Transport Supported by Galileo" is making a significant contribution here with its innovative solutions to integrate navigation, localization and communication systems in logistics systems.

The project started in March of 2007 as part of Saxony-Anhalt's state initiative "Applied Transportation Research/Galileo Transport in Saxony-Anhalt".

Conception

In Best4City, the Fraunhofer Institute for Factory Operation and Automation IFF Magdeburg, the Technical University of Darmstadt and the GZVB Competence Center GmbH Braunschweig are jointly pursuing the goal of utilizing intelligent logistics to relieve downtown areas and thus organize them more attractively for residents, merchants, logistics providers and tourists. A committee of representatives from the federal, state and Magdeburg municipal governments and the logistics industry supporting this research is contributing its practical knowledge of real conditions and requirements to the project. The focus is concentrated on identifying potentials for and constraints on the use of intelligent transport containers, so-called interchangeable trailers, to reduce urban traffic. The intention is to demonstrate the effectiveness of IT



SACHSEN-ANHALT

The study on which this report is based was conducted as part of the R&D project "Best4City: Low Volume Commercial Transport Supported by Galileo" funded by the Federal Ministry of Transport, Building and Urban Affairs and the State of Saxony-Anhalt Ministry of Regional Development and Transportation. (Reference No.: 70.791/2006).



Fig.: Cleverly through downtown with interchangeable trailers. Photo: Herbert Siegert

and technical measures on vehicles and interchangeable trailers. To this end, newly developed interchangeable trailers are being equipped with telematic technologies to make them localizable with satellite navigation systems all the time. This facilitates optimal routing and vehicle utilization as well as ongoing monitoring of the location and condition of goods.

In the first stage of the project, potential demand structures in the domain of low volume commercial transport were assessed and the stakeholders in Saxony-Anhalt active on the supply and demand side were classified according to specific features of their industries. At the same time, the volume of smaller and medium shipments of goods in Magdeburg was analyzed. Interviews with merchants, carrier associations and local logistics providers revealed opportunities for and potentials of the innovative container. Merchants and logistics providers primarily see potentials for the interchangeable trailer in the prospect of combining processes and thus rescheduling the acceptance times of goods. The interchangeable trailer makes goods receiving and shipping processes more flexible and can serve as an alternative temporary storage option. Moreover, this innovative loading equipment increases reliability in logistical processes considerably. With regard to warranty claims and the increasing value of many products, this makes it particularly interesting for logistics providers. Representatives of the city hope that use of interchangeable trailers will above all stimulate business, enhance livability and attractiveness in downtown areas and cut accidents by reducing heavy vehicle traffic through downtown areas.

Results

Based on the findings, a logistics concept was developed, which meets the evaluated demands. The advantages of courier express shipping services, urban logistics concepts and innovative technologies were harmonized in the concept "LOS! Logistics for Cities". LOS! has the interchangeable trailer as a new unit load at its core and allows diverse use scenarios. The basic idea is to reduce the number of large trucks that enter downtown areas. According to LOS!, the goods transported ought to be delivered to handling points, so-called mini-distribution centers, concentrated near a city and delivered in combined small-scale distribution. Combined space is intended to make shipments to and from downtown areas demand-driven and efficient. This increases vehicle utilization and thus reduces the volume of traffic while simultaneously utilizing capacities optimally. Mini-distribution centers must be well connected to the network of interstate highways. The establishment of terminals at downtown train stations and (domestic ports) is conceivable, for instance, as the need for other transport routes than roads increases, .

The Institute of Physical Geodesy at the Technical University of Darmstadt conducted a simulation study to identify future benefits from the use of Galileo for urban logistics. A three-dimensional model of the city of Magdeburg and a software developed at the Technical University of Darmstadt provided the basis to analyze a case study of points in downtown Magdeburg where localization by GPS alone is not at all or only marginally possible. Continuous and reliable localization in downtown areas filled with buildings, trees or the like with high shadowing rates proved to only be possible when GPS is combined with Galileo.

Outlook

Methods to operate the "LOS!" concept are being investigated at present. A planned overall evaluation is expected to identify costs as well as potentials for savings generated by implementing the concept and interfaces with conventional transportation measures. In conclusion, recommendations for the implementation of the model will be formulated, which incorporate both the status quo and specific local conditions of commercial transport in urban Magdeburg and its development and trends. In particular, the establishment of the systematic promotion of centers of expertise and development for telematic transport solutions will be evaluated. The interchangeable trailer equipped with telematics represents an innovative solution to optimize transport operations with the goal of cutting costs and, against the background of debates about environmental policy, points toward the future too.

Project Partners

- Technical University of Darmstadt, Department of Business Management and Logistic
- Technical University of Darmstadt, Department of Astronomical Geodesy and Satellite Navigation
- GZVB Competence Center GmbH, Braunschweig

Project Reports from the
Virtual Engineering Expert Group



Photo: Bernd Müller, Fraunhofer-Gesellschaft

Virtual Optimization and Commissioning of a High Temperature Wood Drying Kiln

Dr. Matthias Gohla
Tel. +49 391/40 90-361
Matthias.Gohla@iff.fraunhofer.de

Torsten Böhme
Tel. +49 391/40 90-234
Torsten.Boehme@iff.fraunhofer.de

Thomas Reek
Tel. +49 391/40 90-203
Thomas.Reek@iff.fraunhofer.de

Initial Situation

Holzindustrie Templin GmbH contracted the construction of a high temperature drying kiln to produce thermowood. This still relatively unfamiliar process subsequently treats untreated wood raw materials after the conventional drying process to reduce adsorption water content to lessen the degree of cellulose polymerization at high temperatures. After the process, the wood raw material not only has a changed color and possibly a raised grain but is also more resistant to attacks from fungi, insects and microorganisms. Thus, treatment with wood preservatives can usually be dispensed with.

Treating every stack of boards under defined conditions not only necessitates complex control and process monitoring but also uniform heating of the product by the gas flowing around it. The process has to be optimized so that a design of minimum size facilitates a uniform flow around a maximum quantity of wood.

Process Engineering Optimization on the Plant Model

Since the stacks of boards absolutely must be subjected to a uniform flow and heating to ensure consistent product quality, the plant's geometry decisively influences the gas flow inside the kiln and thus the treatment process.

The Fluent® software package was used to project flow behavior inside the kiln with a CFD simulation. A volumetric discretization of the flows in equipment and components generates systems of equations that allow mathematically calculating vector flow velocities, pressure losses, local temperatures and much more.

The simulation model was used to optimize flow behavior in the kiln by adjusting its geometry.

Successively implementing these geometric barriers made it possible to obtain a flow completely passing through the



Fig. 1: Charging the high temperature drying kiln. Photo: Torsten Böhme

spaces between the stacks with a sufficiently uniformly distributed gas velocity. The optimization of the process engineering on the simulation model greatly reduced the work of later implementation. The process validated by the simulation cuts time and cost intensive practical tests on the real plant. This not only saves on work required for retrofitting but also material required to charge the kiln during test runs. In addition, the time that would be required for complete runs to dry a product and the setup time in between is also reduced.

Control System Development on the Plant Model: Virtual Commissioning

The simulation of the optimized flow defines the process engineering requirements for later process control. Thus, since the primary objective of the construction of the drying kiln is the availability of a functional plant as fast as possible, control system programming can already begin before the plant is constructed. This means, the control and operating software can be commissioned immediately after the hardware components have been commissioned.

Therefore, the early development of the control system without physically available plant components generates a complete model of the plant's performance. This virtual plant was produced with the real-time simulation program WinMOD[®] and reproduces trigger and check-back signals and the time response and disturbance characteristics of the later plant. The virtual plant not only tests in advance and validates the actual control functions but, above all, also the safety-relevant control functions for process monitoring, process safety and fault and accident management, which make up approximately eighty percent of the control software.

Rigorous virtual commissioning made it possible to produce the control and operating software for the high temperature drying kiln before its construction. The plant was subsequently really commissioned with a control system that had been extensively tested and validated beforehand. The real commissioning of the kiln was largely limited to testing the signals and functions of the sensor and actuator systems. Merely a few changes were made to the program because of final changes to the design of the sensor and actuator systems on site. Consequently, kiln operation with wood could already be run through at the construction site three days later.

Results

The tools of computerized flow simulation allow checking the function of and optimizing process plants. A simulation of the plant's processes enables integrating the designs of control concepts for a plant at an early stage. The technology scheme derived from this can be used to generate a simulation of the performance of the signals to be controlled.

Coupling this real-time simulation with the real control system permits developing the control and operating software very early on in the project and already extensively testing its functions without a real plant.

This project clearly demonstrates that the logical design of process plants supported by simulation can validate the quality of processes at an early stage. Moreover, virtually commissioning the design and extensively testing the control and operating software greatly reduces the time needed to commission plants.

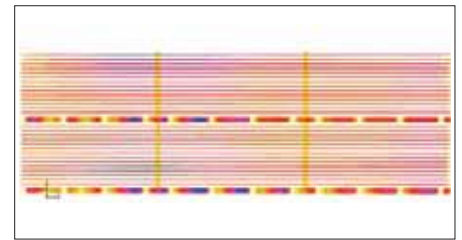

Fig. 2: Lateral view of the distribution of gas velocity toward the y-coordinate with optimized installed components, calculated with Fluent[®].

Project Partner

– Holzindustrie Templin GmbH

VIDET: Fraunhofer Virtual Development, Engineering and Training Innovation Cluster for Regional Large Machinery and Plant Manufacturing Industry

Prof. Michael Schenk
Tel. +49 391/40 90-470
Michael.Schenk@iff.fraunhofer.de

Prof. Ulrich Schmucker
Tel. +49 391/40 90-201
Ulrich.Schmucker@iff.fraunhofer.de

More and more frequently, new products are developed on computers. They are digitally designed, constructed, tested and refined. Engineers may test new machinery on a computer without having to first build expensive prototypes. Manufacturing processes may be run through, potential faults and weaknesses identified and staff trained in interactive 3-D. New methods and technologies such as virtual engineering (VE) and virtual reality (VR) make it possible to reproduce and test new products and their features throughout the entire process chain from product design to manufacturing up through distribution and usage in the virtual world beforehand. Previously, carmakers principally took advantage of virtual planning, development and operation. Henceforth, these technologies will also be implemented more extensively in machinery and plant manufacturing companies in Saxony-Anhalt.

The Virtual Development, Engineering and Training Innovation Cluster (VIDET) has been established at the Fraunhofer IFF to develop and apply the methods, processes and tools needed to do this. The Fraunhofer-Gesellschaft's Innovation Clusters are a core point of the "Pact for Research and Innovation" enacted by the Bund-Länder Commission for Educational Planning and Research Promotion (BLK) in November of 2004 and June of 2005: Following the motto "Strengthening Strengths", regional fields of technology with high potential for innovation will be rigorously nurtured with support from the Federal Ministry for Education and Research (BMBF) and the particular Fraunhofer Institutes' home states. In the Innovation Clusters, regional enterprises and research organizations collaborate closely on concrete research and development projects to turn existing know-how into practical results to enhance regional



Fig.: A real CNC coupled with the virtual model of a heavy machine tool.
Photo: Dirk Mahler

The VIDET Innovation Cluster is being supported by the Federal Ministry of Education and Research.
(Reference No.: IC 09)

businesses competitiveness as rapidly as possible. The Fraunhofer-Gesellschaft has established twelve such Innovation Clusters so far. Others are in planning.

On the basis of years of experience in the fields of virtual reality (VR) and virtual engineering (VE), the VIDET Innovation Cluster at the Fraunhofer IFF in Magdeburg is developing and utilizing applied methods and tools that facilitate the integrated use of VE and VR throughout the product life cycle. Thus, VIDET directly connects basic academic research, applied research in nonacademic organizations and industrial utilization of the results. Special attention is paid to the utility of the methods and tools for small and medium-sized enterprises.

A specific motivation lay behind gearing this Innovation Cluster toward regional machinery and plant manufacturers and the requirements of large machinery and plants in particular.

The territory of present day Saxony-Anhalt and its central and southern regions in particular have been one of the most important centers of the machinery and plant manufacturing and chemical industries since the early days of industrialization in Germany. In the wake of societal transformations in the 1990s and the loss of Eastern European markets, these industries shrank to 10 percent of their original size and had essentially been written off.

Toward the end of the 1990s, new enterprises arose out of this structural crisis, traditional firms restructured and national and international machinery and plant manufacturing companies located here. At the same time, the processing

industry, the primary buyer of the aforementioned industries' products, slowly began to recover.

In the present economic upturn, Saxony-Anhalt's machinery manufacturing industry has experienced strong growth. Each of the last two years brought increases in sales of roughly twenty-five percent. Today, some 14,000 employees - approximately a tenth of the total employment figures - work in machinery manufacturing, approximately an equal number in the metal processing industry and roughly 15,000 in the chemical and chemical plant manufacturing industry. These sectors are definitely driving the positive development at present.

Thus, virtually every third job in the region directly depends on these enterprises' competitiveness and thus the aforementioned industries' products. The product life cycles growing shorter in every sector are forcing companies to constantly innovate and improve products. The times to develop new products and launch their production must be drastically reduced as well. This only succeeds when different targeted measures are combined effectively:

- Use of the latest technologies in product and production development,
- Training of internal R&D staff to work with these technologies,
- Intensified cooperation with R&D organizations, supported by specific public funding of emphasized industries through
- Cooperation in networks of companies and research organizations.

Thus, the VIDET Innovation Cluster provides a regional platform for research and business to collaborate on the development of new products, their manufacturing, commissioning, qualification and training for the regional machinery and plant manufacturing industry. Work is geared toward the requirements of large machinery and plant manufacturers and operators in order to implement research findings in regional businesses as quickly as possible. These include:

- Large machine tools and plants including handling systems,
- Chemical plant and process equipment manufacturing and
- Alternative energy production plants.

The R&D work is being done on three technology platforms:

- Virtual product development,
- Virtual process engineering and
- VR based training and qualification.

A selection of examples of projects already completed by the VIDET Innovation Cluster is described on pages 62-63.

Examples of Applications from the Fraunhofer VIDET Innovation Cluster

Prof. Ulrich Schmucker
Tel. +49 391/40 90-201
Ulrich.Schmucker@iff.fraunhofer.de

Torsten Böhme
Tel. +49 391/40 90-234
Torsten.Boehme@iff.fraunhofer.de

Virtual Development of a New Line of Large Machine Tools to Machine Large Parts

This project involved the integrated “virtual” support of the entire product life cycle of a new large machine tool being developed by industry partner SCHIESS GmbH. Taking VE methods in product engineering as the point of departure, process data is virtually provided to commission and operate such large machinery and test and verify the real prototypes before they exist. Virtual interactive operating and maintenance manuals for the finished system are developed parallel to this.

Since they greatly reduce the effort to localize technical documents, the latter virtual 3-D scenarios benefit globally operating enterprises most.

Electron Beam Welding: A Key Technology for Large Plant Manufacturing of the Future

Industry partner pro-beam AG & Co. KGaA is Europe's technological leader in civil EB welding of large parts. pro-beam not only develops, manufactures and sells its own large chamber units down to small batch scale but also contract manufactures high quality large and special systems.

For and with pro-beam, the lead project is developing virtual methods for product development (EB chambers and systems), process engineering (robot controls, logistics processes) and VR based training (together with SLV Halle GmbH) that are ready for application.



Fig. 1: The project partners in the VIDET Innovation Cluster's subproject “Virtual Development of a New Line of Large Machine Tools to Machine Large Parts” include the Fraunhofer IFF, SCHIESS GmbH in Aschersleben, SYMACON GmbH in Barleben near Magdeburg, Schiess GmbH's regional suppliers and component developers, Otto von Guericke University Magdeburg and ifak in Magdeburg.

The VIDET Innovation Cluster is being supported by the Federal Ministry of Education and Research.
(Reference No.: IC 09)

Visual-interactive Documentation to Support Operational Processes

These virtual process engineering projects are focused on integrating digital models and methods to optimize operator processes.

The goal is to produce and establish a technological basis to utilize standardized and integrated information and know-how storage systems to compile contents of technical documents, manage them and utilize them in processes. Such storage systems are intended to be configured, "maintained" and implemented collaboratively by manufacturers and operators of processing plants to directly support operational processes such as servicing and maintenance. Interactive 3-D visualizations are employed in different operational processes both to repre-

sent contents and to access technical documents. The emphasis is on utilizing the information and know-how storage system to generate interactive, technical documents.

VR Based and Simulation-supported Training Platform for Handling System Operators

Training platforms are being developed for companies that operate handling systems, which can be used to conduct operator training on virtual equipment. To rapidly commission and reliably operate large machinery, operators of handling systems need personnel qualified in operation and safety. Regularly conducted qualification measures related to their systems are essential to fulfill these requirements. Thus, it is particularly interesting for handling system manufacturers to extend their services with options for operator training and simultaneously generate more value added with their specific systems know-how. In addition, handling system manufacturers will be enabled to provide VR training platforms for operator training as a service with their equipment.

The advantage is the low level of prior technical knowledge required from personnel. Thus, the employees' different levels of knowledge can be actively factored in when their knowledge is being successively built up in training. The development of such platforms can basically encompass the reproduction of a handling system with all its kinematics and its work environment, the development of an interface between operator controls and the model, the integration of sound in the form of ambient noises and the implementation of training scenarios.

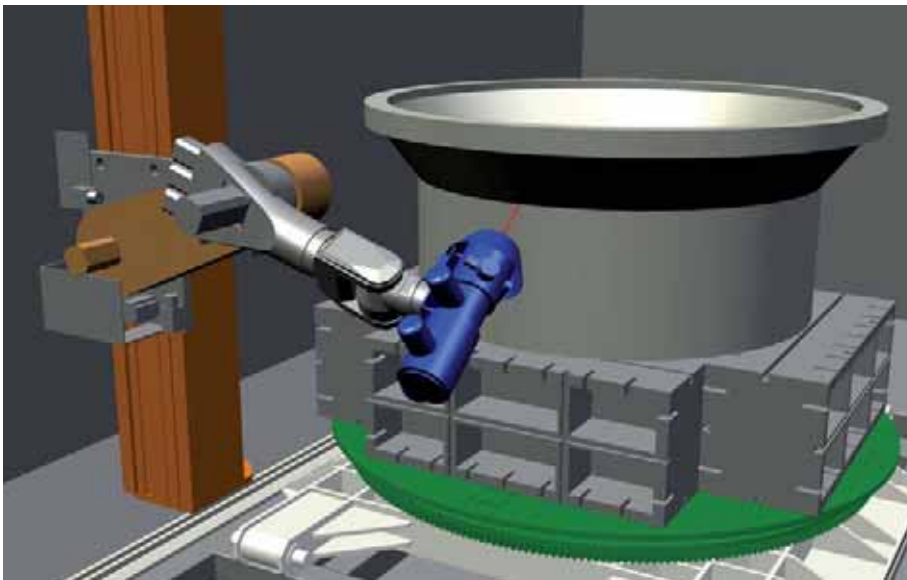

Fig. 2: pro-beam AG & Co. KGaA in Burg, SLV Halle GmbH, Otto von Guericke University Magdeburg and FEMCOS GmbH are actively collaborating with the researchers from the Fraunhofer IFF on the project "Electron Beam Welding: A Key Technology for Large Plant Manufacturing of the Future".

Automatic Generation of Multibody Models: A Contribution to Integrated Virtual Engineering

Tamás Juhász
Tel. +49 391/40 90-206
Tamas.Juhasz@iff.fraunhofer.de

Initial Situation

The automotive industry is a fundamental driver behind the evolution of new virtual technologies for product development. Several disciplines already have to verify and optimize product features in parallel through modeling and simulation at an early stage. This development inevitably means that, in the future, small and medium-sized enterprises in the supplier industry will also have to virtually develop and test their systems and provide virtual models of their components' geometry and function long before manufacturing commences. This makes it possible to jointly simulate and test every subcomponent in advance.

A functional model and dynamic simulation serve as the basis to optimize a virtual product's parameters. The process of configuring such functional multibody models is part of the integrated workflow in the product development process. This workflow is normally run through several times to optimize a product's features iteratively. This confronts small and medium-sized with great challenges because their own developers are normally not familiar enough with the modeling and simulation of the performance of complex systems. The transition from the CAD world to the simulated world requires suitable and tools customized to needs (range of functions, operability, price), which, taking established development environments as their starting point (e.g. engineering CAD), would support the configuration of a cross-domain functional model.

The objective of the project was to develop a method (including a new software tool) that would largely automate this workflow.

Approach

Virtual engineering developed in a CAD system has several parameters defined by users. Since they are optimized through simulation aided by an iterative process, these parameters may vary during development.

The geometry and kinematic (joints and components' position and orientation) and dynamic (masses, inertias) parameters of a current design form the initial basis for a multibody model. This information is extracted from a CAD system to configure the model of a multibody system (MBS) and analyze the dynamic performance of a structure through simulation.

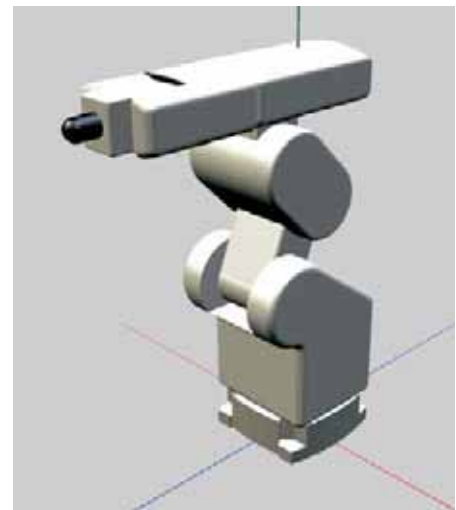

Fig. 1: Model of a Mitsubishi RV-E3J robot arm.

An analysis of a mechanical structure's dynamics requires external sources of energy that set the structure in motion. Apart from gravity, the energy ought to stem from other domains, e.g. electro-mechanics, pneumatics or hydraulics. In addition, a multibody system must be completed as a cross-domain model.

The commercial cross-domain simulation tool Dymola has recently established itself because of its capabilities and acceptance in industry. It is based on the object-oriented Modelica modeling language. Modelica can describe interdisciplinary problems in a broad range of subdisciplines: Mechanics, electrical engineering and electronics, thermodynamics, hydraulics and pneumatics and control and process engineering.

Therefore, the goal was to automate the workflow between CAD software for engineering and Dymola.

Results

The Fraunhofer IFF developed the new cross-domain modeling tool RobotMax to achieve this objective. This software automatically generates an internal multibody model on the basis of the information imported from the CAD system Pro/ENGINEER.

The internal RobotMax model can be completed with elements from an extensible cross-domain model library. A thusly formulated cross-domain model is translated with Modelica into two independent main models (mechanical design and another domain) and exported. Thus, RobotMax makes an automatic workflow between Pro/ENGINEER and Dymola possible. Structures such as the robot arm pictured in Fig. 1 can be rapidly and uncomplicatedly converted with Modelica and simulated with Dymola. Fig. 2 presents the torques of the first three axes during a planned motion.

Outlook

An integrated solution to generate and simulate MBS models in a CAD environment can increase productivity in development significantly.

State-of-the-art CAD systems provide software developers different function libraries and interfaces to extend the development environment with user-specific functions.

Other steps are planned to extract RobotMax's core functionality and integrate it in CAD systems as an extension module.

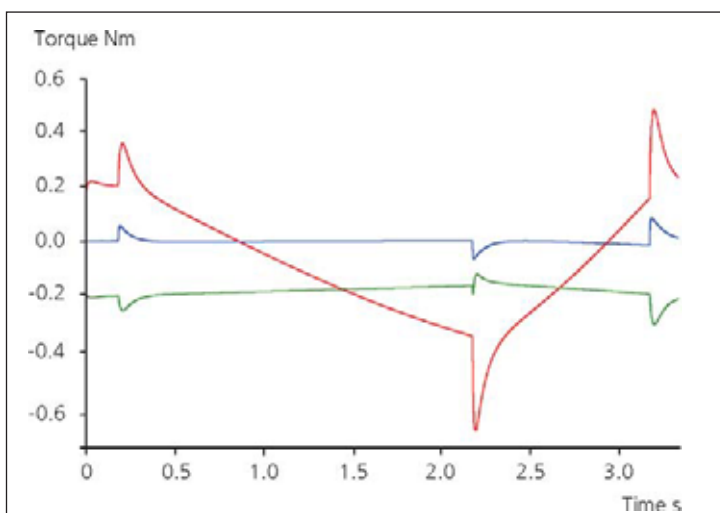

Fig. 2: Results of the Dymola simulation of the moving robot arm.

Hollow Profiles for State-of-the-Art Lightweight Construction

Susan Gronwald
Tel. +49 391/40 90-820
Susan.Gronwald@iff.fraunhofer.de

Motivation

Fiber composites are high strength lightweight materials with a very broad range of uses. Their mass production is difficult to automate however and both simpler and complex components still require a great deal of manual labor. This is why, this all-round talent is frequently encountered in job and small batch production.

Therefore, the regional growth core Alliance for Fiber Composites ALFA is aiming to make the widest variety of fiber composite products and technology developments "fit" for cost effective mass production. To this end, numerous projects with eighteen industry and research partners from the Haldensleben region are promoting technology, material and product developments.

One of the projects on which the Fraunhofer IFF is collaborating is developing a technology for the mass production of high strength but nonetheless cost effective hollow profiles. Project partners are Otto von Guericke University in Magdeburg, H&B Omega Europa GmbH in Osterweddingen and Bär Innovations-Zentrum Mineralguss in Haldensleben. The Fraunhofer IFF's experts in automation, process engineering and database development are involved.

Approach

The project's basic objective is to manufacture novel, high strength composite hollow profiles with flexibly formable cross sections. Until now, it has not been possible to manufacture such profiles with flexible cross sections in an endless process. An automatic, sensor monitored process will be implemented in several stages of the process as will customer friendly support to select the engineered sizes of complex structures .

This entails elaborate calculations that simplify a customer's selection from a large number of different hollow profile cross sections and potential strengths. Hollow profile manufacturing technology is modularly designed, to allow optimizing and flexibly organizing the individual process steps. Hollow profiles are flexibly formed by using inserts to determine their shape. Inserts are interconnected high strength fiber composite rods that can be wound with different taping or roving materials. The option of using different winding and impregnating materials, e.g. glass, aramid or carbon fibers, and a wide variety of impregnating resins, produces widely varying ranges of features applicable to hollow profiles. Moreover, varied winding angles and insert spacing can greatly alter profiles' strengths.

The project "ALFA Hollow Profiles" is being supported by the federal Ministry of Education and Research as part of the regional growth core Alliance for Fiber Composites ALFA.
(Reference No.: 03 WK X02A)

Results

Another interesting solution was seized on to connect hollow profiles. The design allows assembling various complex structures distinguished not only by their high strength but also their low weight.

One interesting application for hollow profiles is window frame manufacturing. Composites have sufficient strength to replace the steel inserts previously used and are only a fraction of their weight. Thus, completely new window shapes can be implemented, which were previously difficult because of the high weight when covering large areas.

Apart from the construction industry, their use to manufacture furniture or exhibition stands is also conceivable. Their marketing as a modular system opens the widest variety of possibilities.

This project kicked off in June 2006 and its development received a successful review in October 2007. More of the results of the growth core's project will be presented at a professional conference at the Zentrum für Faserverbünde in Haldensleben at the end of May 2008.

Project Partners

- Otto von Guericke University Magdeburg, IFME
- H&B Omega Europa GmbH, Osterweddingen
- Bär Innovations-Zentrum Mineralguss, Haldensleben

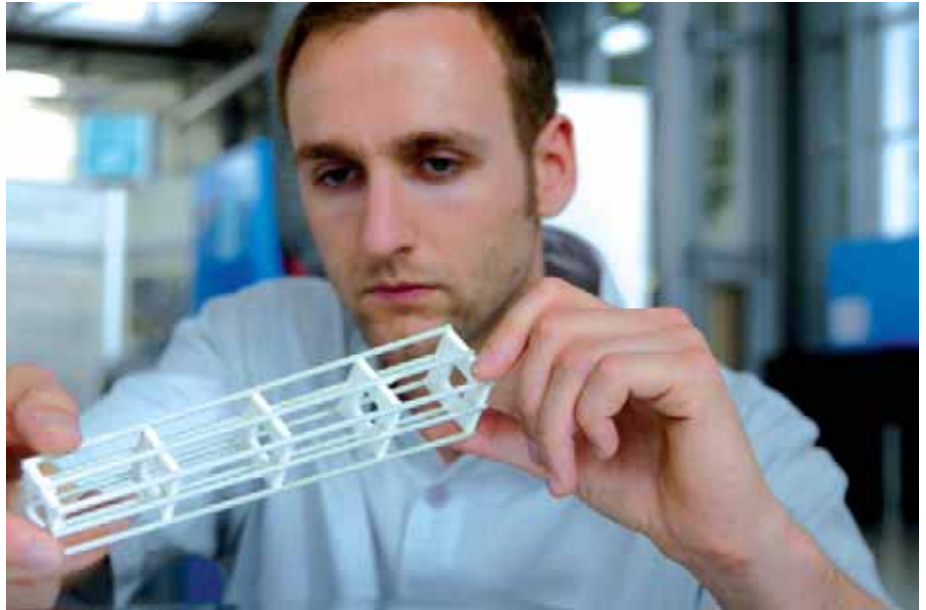

Fig. 1: An unwrapped hollow profile with a variable cross section.
Photo: Anna-Kristina Wassilew

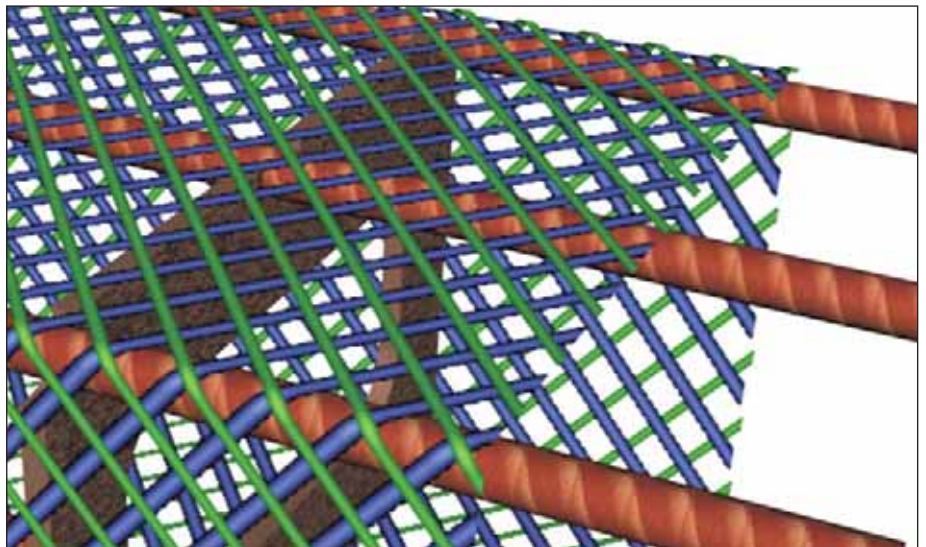

Fig. 2: The structure of a rectangular hollow profile.

Project Reports from the
Virtual Prototyping Expert Group



Service of the Future: Interactive 3-D Operator Manuals

Dr. Rüdiger Mecke
Tel. +49 391/40 90-146
Ruediger.Mecke@iff.fraunhofer.de

Ronny Franke
Tel. +49 391/40 90-144
Ronny.Franke@iff.fraunhofer.de

Initial Situation

Printed operator and maintenance manuals are an integral part of such technical products as machinery, plants, auxiliary equipment, etc. The complexity of certain products is increasingly necessitating the use of digital technologies that surpass conventional manuals and static 2-D illustrations.

Machinery manufacturer Bernard Krone GmbH and the Fraunhofer IFF are working together on the future field of interactive 3-D operator manuals. In conjunction with this, a conventional manual for a forage harvester was partially converted into an interactive 3-D visualization and processed to convey information on conversion measures for the agricultural equipment division. The intention was to create an operator manual that enables users to quickly and easily learn about assembly or disassembly procedures, especially in situations in which equipment's overall space is difficult to view.

The outcome was intended to be adaptable to users' needs and facilitate independent learning of know-how.

Approach

CAD data and information from the operator manual were drawn upon to produce an interactive 3-D operator manual on agricultural equipment conversion. First, the 3-D geometries were imported from the CAD tool into a virtual-interactive system of the Fraunhofer IFF. This enabled quickly and easily providing a virtual model to explore relevant assemblies and tools. Afterward, the operator procedures to be taught from the operator manual were depicted and an interactive presentation produced, which demonstrates retrofits step-by-step with texts and images from the conventional manual and views and animations in the 3-D model. This generated a functional, interactive virtual reality (VR) model with which users can learn specific skills they can directly transfer to the real equipment. A fundamental added value is the clear communication of work steps and operations and the ability to execute them in direct interaction with the digital model. This enables realistically learning and practicing complex work procedures.



Fig 1: Conventional operator manual.

Results

The interactive 3-D operator manual can be employed in service and operator training. Complex retrofitting process can be taught with clarity, especially when equipment's overall space is difficult to view. What is more, such a model facilitates independent learning. Equipment operators can retrieve clear instructions rapidly and systematically and thus avoid operating errors on real equipment.

Since it simply and vividly communicates the operation of machinery to potential clients, such a 3-D manual also benefits marketing. It effectively supported KRONE's presentation at AGRITECHNICA 2007, the world's largest farm equipment show. An interactive 3-D manual answered many questions from potential and even existing customers.

Outlook

The interactive 3-D operator manual produced can run on a variety of hardware, e.g. PC, laptops, PDA and stereo projection systems. Thus, it is also conceivable that such media could act as an on site support, e.g. as an Internet variant or on a PDA, with which problems could be resolved directly where they occur.

Project Partner

- Maschinenfabrik Bernard Krone GmbH, Spelle



Fig. 2 and Fig. 3:
Views from the interactive
3-D operator manual.
Photo: Rüdiger Mecke

Fig. 4 and Fig. 5:
The 3-D stereo projection
integrated in KRONE's booth drew
crowds at AGRITECHNICA 2007.
Photos: Rüdiger Mecke



Interactive 3-D Visualization: Detailed Bathroom Planning

Andreas Höpfner
Tel. +49 391/40 90-116
Andreas.Höpfner@iff.fraunhofer.de

Ronny Franke
Tel +49 391/40 90-144
Ronny.Franke@iff.fraunhofer.de

Dr. Rüdiger Mecke
Tel. +49 391/40 90-146
Ruediger.Mecke@iff.fraunhofer.de

Motivation

Bathrooms in private residences are increasingly evolving from classical functional spaces into places of relaxation and repose. This is closely tied to a desire for high quality interior designs. New building materials (tiles, natural stone, creative wall design) and bathroom equipment and combinations thereof are diversifying the options. Bathrooms additionally entail extremely complex installations to supply and dispose of different media. This is also true of public bathrooms. The new construction of, addition to or remodeling of such "wellness oases" often require far higher investment than other (living) spaces.

Understandably, a potential client of such construction work desires to already clarify as many questions as possible with the contractor in the planning phase and verify the proposed design to the greatest extent possible. Especially for private clients, emotional aspects such as personal identification proposed design and confidence in the contractor also play a significant role in decisions about such an investment. These are reasons computer planning has become a standard supporting service, especially in the higher price range. A number of CAD program generate photorealistic design alternatives for bathroom planning. Normally, a monitor or projector visualizes the results two-dimensionally.

While this is better than a printed copy, it lacks the sense of reality that significantly influences a decision to buy. A 3-D bathroom planning specialist, tiling contractor and tile retailer, Fliesen-Schreiber GmbH in Rieder approached the Fraunhofer IFF with this problem. Both partners have agreed to cooperate to find a solution.

Approach

CAD planning systems' dissemination and functionalities for bathroom planning were initially researched. The existence of relevant databases containing specific manufacturers' 3-D datasets of materials (tiles, wall finishing), sanitary equipment and fixtures was a fundamental criterion. The tile and bathroom sector proved to be very advanced as regards standardization and the dissemination of digital product information. Nearly all reputable manufacturers have digital data models of their products, which service providers, e.g. ARGE Neue Medien, tested and provided standardized. These digital models constitute the base of data for 3-D bathroom planning programs. Interfaces to export 3-D planning datasets to virtual reality systems have been developed for select planning programs. VRML is the underlying exchange format. System-specific interpretations of the format were appropriately incorporated. Large format stereo projection is used as the visualization environment. This gives users the sensation of standing in the middle of their

new bathroom. They merely have to put on stereo glasses and all the details appear in virtual reality (VR) photorealistically and with spatial depth.

Thus, the spatial dimensions of a planned bathroom can be visualized especially well. The customer service rep who created the 3-D design directs the interaction with the virtual environment. Customers may also use an interaction device to explore their potential bathroom on their own. Various planning and design alternatives can be tested. Interaction with a virtual bathroom is also possible, e.g. cupboard doors or the shower stall can be opened or fixtures operated.

Results and Benefits

The Fraunhofer IFF developed a new virtual reality visualization system with interfaces for different bathroom planning programs. 3-D contents are projected frontally onto a large format screen (approx. 2.3 x 1.7 m). The system was installed in an exhibition room at Fliesen-Schreiber GmbH in November 2007 and, since then, has been effectively been in use as a tool for discussing customer wishes. The positive experiences with the use of the system bear out the approach pursued to provide customers support when they are making a buying decision through the special experience of realistically experiencing their bathroom in virtual reality beforehand.

Outlook

The two partners are collaborating on further developing the interactive 3-D visualization system and Fliesen-Schreiber GmbH is marketing it under the name Living Vision.

Apart from further software developments, e.g. to enhance the photorealistic representation, other work is being done to transfer the visualization to immersive multisided projection systems. Among other things, their projection of the floor intensifies the perceived degree of immersion in virtual reality. In the long-term, this strategic partnership will be extended to include manufacturers of CAD planning programs.



Fig.: Visualization of a bathroom design in an immersive multisided projection system (CAVE) at the Fraunhofer IFF. Photo: Dirk Mahler

Project Partner

- Fliesen-Schreiber GmbH, Rieder



SACHSEN-ANHALT

Virtual Technologies Represent Complex Markets

Dr. Gerhard Müller
Tel. +49 391/40 90-401
Gerhard.Mueller@iff.fraunhofer.de

Andreas Höpfner
Tel. +49 391/40 90-116
Andreas.Hoepfner@iff.fraunhofer.de

Motivation

Saxony-Anhalt's economy has experienced a deep seated structural transformation in recent years. The entire region's image has been refashioned and the state has turned into an innovative, future-oriented center of business. The innovations and potentials created, especially internationally, are other positive developments constituting unique selling points of the state. Foreign trade is especially playing an important role at present. Hence the state's Ministry of Economics has made it a priority issue.

The objective of this project was to clearly present Saxony-Anhalt's market, which is continually growing more complex, and represent its depth so that issues can be comprehended quickly at international meetings and the presentation is guaranteed to leave a lasting impression on audiences.

The virtual technologies the Fraunhofer IFF develops are ideally suited to support an entirely new form of external presentation for the entire region.

Approach

A 3-D representation of the state of Saxony-Anhalt forms the basis for the visualization concept's multilevel model approach. Users may select between different viewing scales and progress from an overview presentation of the entire region to reach levels representing individual locations, down to levels of virtual factories or products. Thus, the system enables entering the virtual world through a specific thematic focus. Users may select a theme from the overall economic context and view it in the aforementioned levels of detail (state, location, plant and product levels) or systematically present its contents.

Intuitive operator elements and a targeted navigation option are the prerequisites to effective practical application. The topic of renewable energies provides an excellent example. Users use the interaction element of the "energy matrix" to intuitively and specifically retrieve more information. Figures 1-3 illustrate the transfer of this sector's real world structures into the interaction concept of virtual reality. Given its inherent structure, this already organizes navigation in the virtual world to be intuitive and easy to learn. Users can move very purposefully within a specific topic and, for instance, represent relationships and synergy effects between research and industrial application. The basic idea behind intuitive interaction as demonstrated by this example is scalable in its application and equally transferrable to other thematic domains.

The project to represent complex markets is being supported by the State of Saxony-Anhalt with funds from the European Fund for Regional Development.
(Reference No.: 6.12.1.07.00021)

Results and Benefits

The approach described reveals a crucial advantage of the system. This innovative form of presentation is not limited to representing predefined contents and does not restrict informational content from the outset. Rather it enables users to act extremely flexibly in a photorealistic 3-D environment. Contents can be freely defined by users and optimally adapted during the course of a presentation or potential questions.

The industry-related view of the entire market in conjunction with the system's different levels of representation additionally allow drawing inferences about concrete advantages of individual economic locations from the overall economic context. Thus, not only do partners in talks and presentation audiences quickly grasp the issues but a tool is also provided, which, for example, makes sound arguments for involvement in the state of Saxony-Anhalt retrievable and comprehensible when business decisions are being made.

Various methods of presentation are available. The Elbe Dom in the Fraunhofer IFF VDTC furnishes an exclusive setting for photorealistic real-time presentation on a scale of 1:1. This method of presentation is ideally suited for receptions of international business partners and investors to discuss options for future activity. Mobile 3-D projection with stereoscopic presentation is preferable for mobile use, e.g. at international trade shows. The software can run on laptops as well as projectors and thus guarantees maximum flexibility.

Innovative technologies effectively present an innovative market in its complexity and entire spectrum of different viewing scales. In conjunction with the different methods of presentation, the visualization concept's extensibility guarantees diverse and sustainable applications in practice.

Collaboration

Depicting a region's economic relationships in virtual reality necessitates involving the entire network of businesses and political actors in the project work. The initial contact and client was the State of Saxony-Anhalt, represented by the Ministry of Economics and Labor. Aided by its relevant departments, the foreign trade division compiled all the requisite information and statistical surveys from the state, placed them in an international context and thus prepared the substantive basis of the visualization project.

Since the multilayer model approach specifies information down to a detailed level, the optimal presentation of individual themes is developed in direct collaboration with the various companies, research organizations and users. Only this holistic approach enables effective project work and simultaneously establishes the foundation to sustainably maintain and potentially upgrade the results obtained.

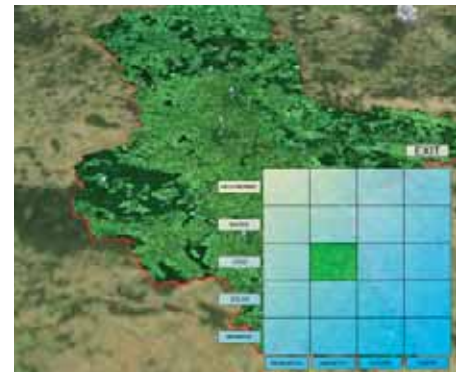

Fig. 1: Matrix of the virtual energy map of Saxony-Anhalt (here, renewable energies)



Fig. 2: Detail of the virtual energy map of Saxony-Anhalt (here, renewable energies > wind power > companies > Enercon)



Fig. 3: A virtual bird's eye view of Enercon's premises in north Magdeburg.

Project Reports from the
Virtual-Interactive Training Business Unit

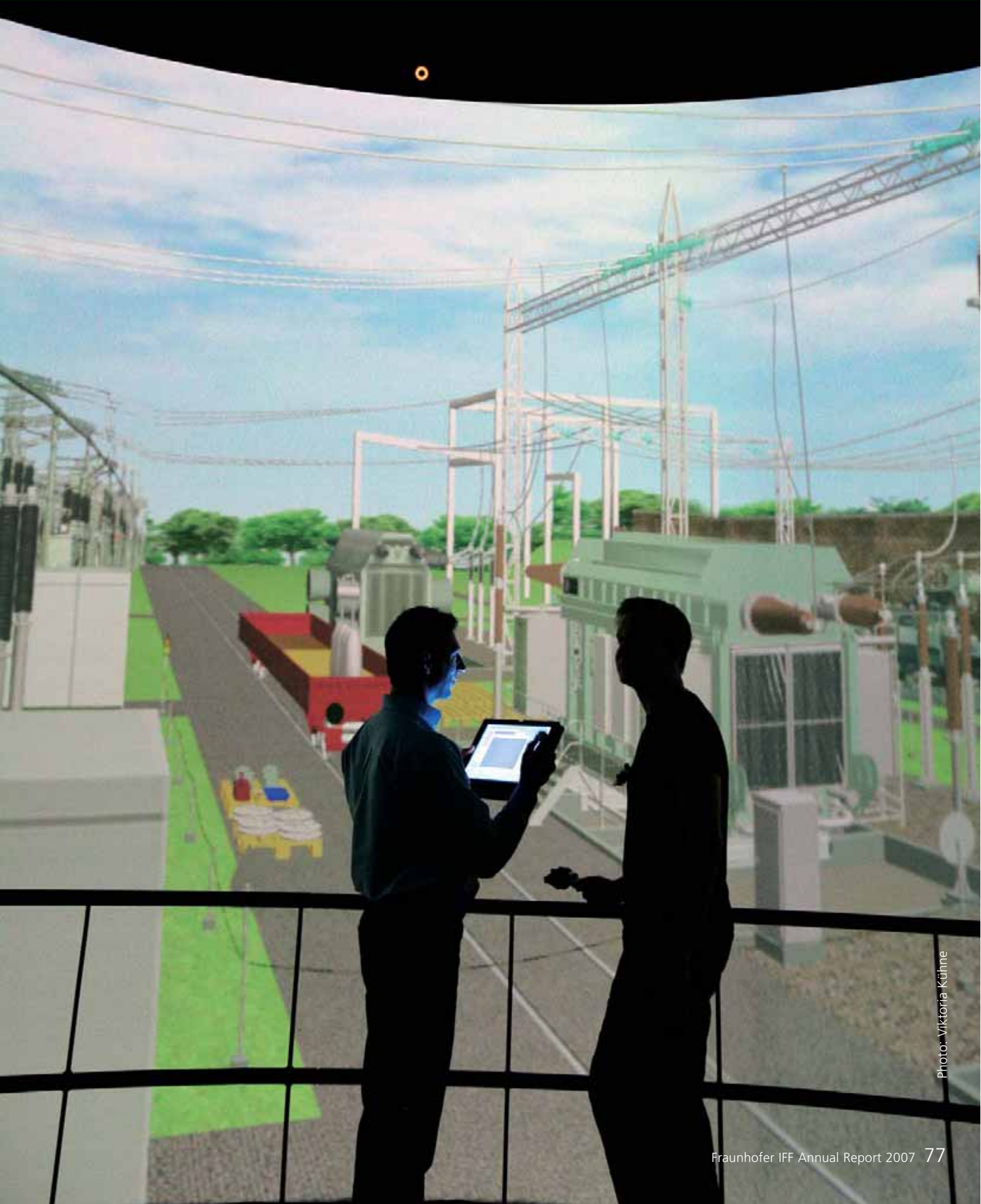

Photo: Viktoria Kühne

Using Computer Simulated Production Scenarios to Sustainably Organize Production Processes

Wilhelm Termath
Tel. +49 391/40 90-129
Wilhelm.Termath@iff.fraunhofer.de

Initial Situation

Throughout the world, sustainable development is being intensively discussed as an educational goal. The Agenda 21 plan of action adopted by the United Nations in Rio de Janeiro in 1992 describes a vision of sustainable action in modern industrial society. A strategy was agreed upon, which pursues ecological, economic and social developments in equal measure - and does so in a process of lifelong learning.

The Federal Institute for Vocational Education and Training has started a series of projects to develop concepts for sustainable learning in different domains of basic and advance training for skilled labor. The subject of one pilot project being carried out in Duisburg with the

involvement of the Fraunhofer IFF is sustainable action for company experts and executives.

A major problem with regard to promoting action oriented toward sustainability is that the effects of trainees' on-the-job actions can usually only be explained theoretically and hypothetically since there is no opportunity for empirical verification and review. Teaching sustainability particularly requires accentuating the medium and long range effects of on-the-job actions and decisions in conjunction with their technical, social and ecological impacts.

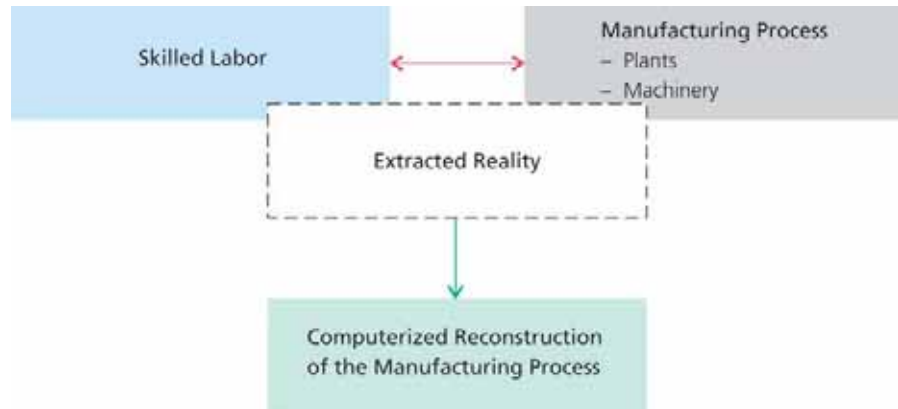

Fig. 1: The concept of computer simulated industrial manufacturing processes.

The pilot project "Promoting Sustainable Action among Mid-level Executives" is being supported by the Federal Ministry of Education and Research through the Federal Institute for Vocational Education and Training.
(Reference No.: D 6138.00)

Approach

Computerized learning environments enable trainees to act in virtual company reality. This approach counteracts the limitations that arise from insufficient feedback.

The starting point for this approach is the development of situations in a real manufacturing process or certain segments of such a process requiring action as the basis of the learning process. The trainees' task is to further improve the virtual process continuously, identify existing weak points and optimize the process as far as possible. Trainees are able to exert influence on the organization of a manufacturing process in discrete intervals by making different decisions.

The model project developed a concept for a new learning module based on a simulated manufacturing process in a foundry, which, in turn, forms the basis of a computerized learning environment with which skills for on-the-job action can be nurtured systematically.

The trainees' task is to further improve the process and identify and eliminate existing weak points. They are able to influence the manufacturing process in discrete intervals by taking different actions.

Results and Benefits

The simulation delivers concrete company indicators for various domains. These parameters clarify the effects of actions, which in reality would become manifest at a point in the future not entirely clear at the moment. Trainees utilize concrete parameters, e.g. staff assignments, equipment selection, etc., to influence the organization of the overall process. A user manual contains a description of the model firm, assignments and diverse tips as supporting materials to test different scenarios. Instructors supervise learning. They receive a comprehensive instructor manual as a teaching aid. In addition, documents, which trainees may use as supplementary materials, can be incorporated into the software.

Project Partners

- Sponsor
Bildungszentrum der Wirtschaft am Niederrhein gGmbH (BZN)
- Academic Support
Otto von Guericke University Magdeburg
- Media Concept
AalenUniversity of Applied Sciences
- Media Development
Fraunhofer Institute for Factory Operation and Automation IFF

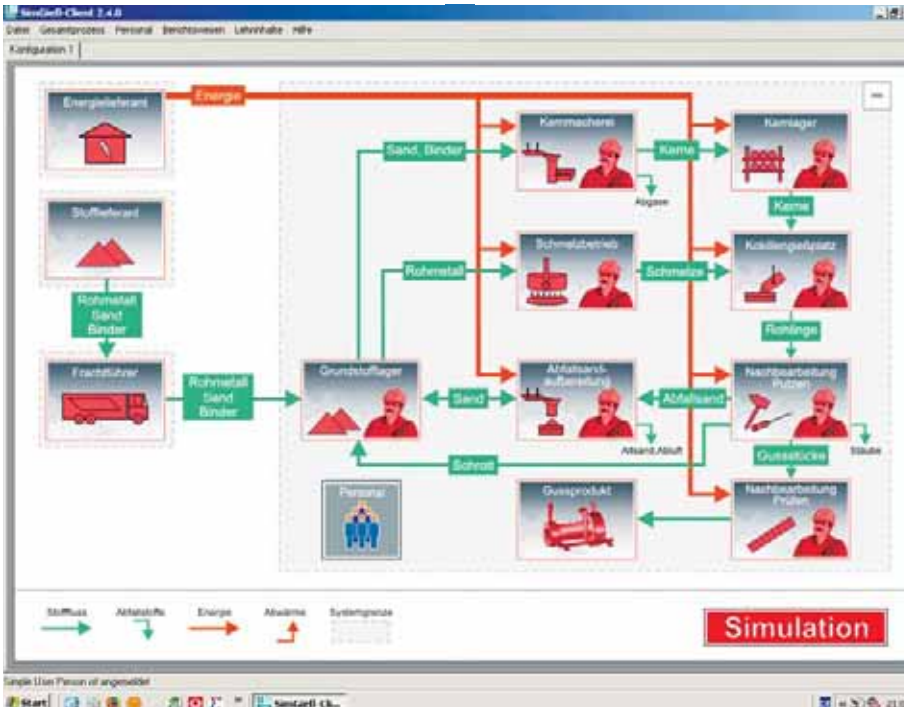

Fig. 2: The main systems and subsystems of a computer simulated model foundry.

High Voltage Equipment Maintenance: The Challenge of Qualifying Technical Experts

Wilhelm Termath
Tel. +49 391/40 90-129
Wilhelm.Termath@iff.fraunhofer.de

Initial Situation

Technik Center Primärtechnik is an organizational unit of RWE Rhein-Ruhr Netzservice GmbH headquartered in Wesel. It performs maintenance work on high voltage equipment such as circuit breakers and disconnectors including mobile network transformers of up to 380 kilovolt in its shops and at all RWE high voltage switching stations. In addition, the service staff performs standard services on this equipment in the individual regions supplied by RWE.

Training and near real-time information as well as technical support for staff throughout the concern assure the quality of maintenance work being performed.

In general, the specific aspects of high voltage equipment set the basic conditions for the Technik Center's work and for training actions in particular. Some of these aspects are formulated here:

- Pertinent safety regulations must be observed whenever inspection, servicing, maintenance and improvement work is being performed.

- For reasons of safety and because it is integrated in national or international power grid structures, equipment cannot be utilized for training while it is operating.
- The functional processes inside equipment cannot be observed.
- The equipment's decades-long service life necessitates developing the know-how of the technical specialists for the company.

Approach and Solution

The overall objective of the project is to develop interactive models of the equipment, which serve as an infrastructure for demonstration and education and as a medium to secure and provide knowledge and information. The potentials of interactive VR technologies are being taken advantage of to broaden the Technik Center's range of services.

Equipment's function and mode of operation, e.g. high voltage power circuit breakers in large transformers, are not visible in reality and only experientable through their effects. A virtual environment can visualize forces and physical



Fig. 1: A 200 MVA mobile network transformer in RWE Netzservice's Niederrhein switching station and as a VR graphic on the right. Photo: Wilhelm Termath

processes so that slow motion makes all the details and subprocesses distinguishable. The basic functions of a large transformer's active core can be presented by representing the pipelines, windings and circuits as well as the power and oil flows. Beyond the generally introduction to the equipment, the basic work processes and main work of inspection, servicing, repair and improvement are safely learned and practiced in the virtual world

In a first collaborative step, a unit is being created to train the preparation of a large transformer for transport on public roads or by rail. The add-on parts necessary for transformer operation, e.g. bushings and diffusers, have to be removed to comply with the allowable dimensions stipulated by the Deutsche Bahn. The experts from the Technik Center documented the basic work steps to do this beforehand. This workflow description then formed the basis for the script to develop the learning unit, which was jointly compiled afterward.

Results and Benefits

The entire work process was divided into six subprocesses from setting up and protecting the work area through disassembling subsystems that exceed the profile allowed by the Deutsche Bahn. Difficult work steps were given particular emphasis. In a training situation, the work processes are first presented on the virtual model and then completed independently.

The use of these learning scenarios in seminars for technical experts fully met the expectations of everyone involved. The technical experts accepted the virtual interactive learning scenario as a medium. The jointly compiled script is a particular benefit.

Several experts contributed their specific know-how and experience. Thus, the visualization represents a best practice solution accepted by everyone.

Outlook

In light of the positive experience, RWE Technik Center Primärtechnik and the Fraunhofer IFF intend to continue and expand their collaboration. A next step is intended to develop the virtual interactive scenario together with the manufacturers of the high voltage equipment. Using the 3-D engineering data will substantially reduce the work required to create the scenario and enable developing other related uses such as installation, commissioning and maintenance.

Project Partner

- RWE Rhein-Ruhr Netzservice GmbH, Technik Center Primärtechnik, Wesel

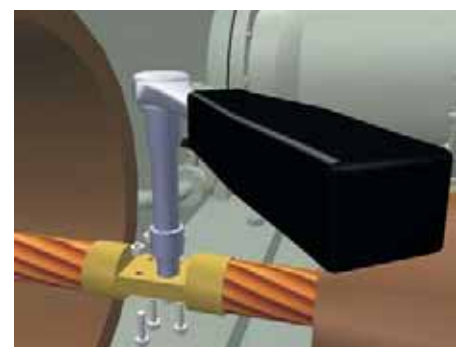
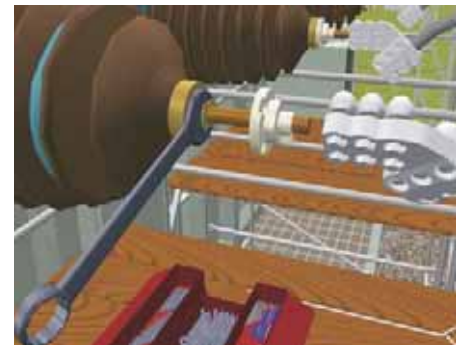

Fig. 2: VR representations of the disassembly of bushings and diffusers.



Product Development Based on a Semantic Virtual Engineering Environment

Matthias Strauchmann
Tel. +49 391/40 90-114
Matthias.Strauchmann@iff.fraunhofer.de

Tina Haase
Tel. +49 391/40 90-162
Tina.Haase@iff.fraunhofer.de

Motivation

Given the increasing orientation toward customers, the development and manufacturing of complex technical products are significantly shaping the processes of product development. Product development also includes R&D processes, which are increasingly executed in team oriented and interdisciplinary project work. In these complex and time-critical processes, researchers and developers develop knowledge about products, technology and processes, which would be of use in other projects. The physical separation of different development teams and the use of different IT systems produce islands of information and knowledge. This impedes the flow of knowledge inside an organization. Consequently, development teams face the challenge of utilizing and efficiently reutilizing existing product knowledge cross-team and cross-company.

The project SEVENPRO is concerned with improving product development processes in engineering and manufacturing by semantically recording and formalizing and ontologically managing product knowledge. At present, many engineering tools are used separately. The implementation of a semantic metadata layer will make it possible to provide all relevant information in one integrated environment (Fig. 1).

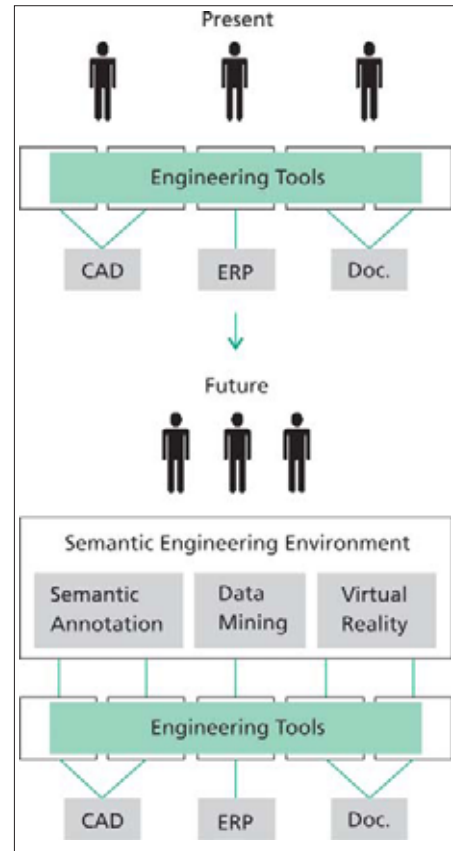

Fig. 1: The concept for integrating product development processes.

Approach

The project is pursuing an ontological approach to modeling the knowledge base. The ontologies describe the context of utilization and serve as the basis for automatic or semiautomatic annotation of various existing data sources. The semantic technology does not replace by existing systems, e.g. enterprise resource planning (ERP), product data management (PDM), product life cycle management (PLM) systems. Rather, ontologies integrate them in the knowledge base.

SEVENPRO is being supported by the EU in the 6th Framework Programme and runs from January 1, 2006 through October 31, 2008 (Reference No.: FP6-027473)

The central concept is items. Items are manageable components of a product, which are entered in an ERP and may correspond to parts of the product structure. Accordingly, products are highest level items.

The semantic database is the central element in the system architecture. Ontologies form the basis for data storage by defining the structure of the data being stored. Semantic metadata is stored by so-called annotation modules, which allow automatically or semiautomatically annotating different data sources. The emphasis is on annotating CAD models, ERP sources and text documents. The information relevant according to the ontologies is extracted from the extremely large quantity of data generated during the engineering process.

The semantic communication and access module is the interface to the semantic database for every module. It controls

the execution of the annotation modules and regulates and monitors the client module data access. The client modules include the following:

- The Semantic Engineering Module enables creating new products, managing product data and searching for product information in data sources.
- The Storage Module supports the retrieval of existing solutions from past projects.
- The Semantic VR Module furnishes an interactive environment to virtually represent products. It provides intuitive options to access the knowledge base.
- The VR Control Module uses rule-based access to model data to control objects' behavior in a virtual scene.
- The Data Mining Module enables searching for hidden design patterns in the semantic knowledge base. Found patterns are stored and thus available to the other modules.

Goals and Outlook

The conceptual solution is first being evaluated in two user scenarios based on requirements predefined by a medium-sized enterprise and a large engineering firm. The following criteria are being analyzed in both scenarios:

- Easy product configuration and visualization,
- Knowledge transfer from the design to the manufacturing phase,
- Knowledge transfer between engineers with different profiles and
- User friendliness of the semantic search machine, e.g. when searching for similar, already existing designs on the basis of reference features.

In the further course of the project, it will be essential to identify the potentials of combined semantic technology, virtual reality and data mining in the field of application and to appropriately implement the user requirements. The goal will be to establish interactive knowledge transfer modules and to eliminate islands of information in the company.

Project Partners

- Fraunhofer-Gesellschaft, Munich
- Semantic Systems S.A., Spain
- Institut National de Recherche en Informatique et en Automatique, France
- Ceske Vysoke Ucení Technické v Praze, Czech Republic
- Italdesign – Giugiaro S.P.A., Italy
- Fundiciones del Estanda, Spain
- Livingsolids GMBH, Wolfsburg

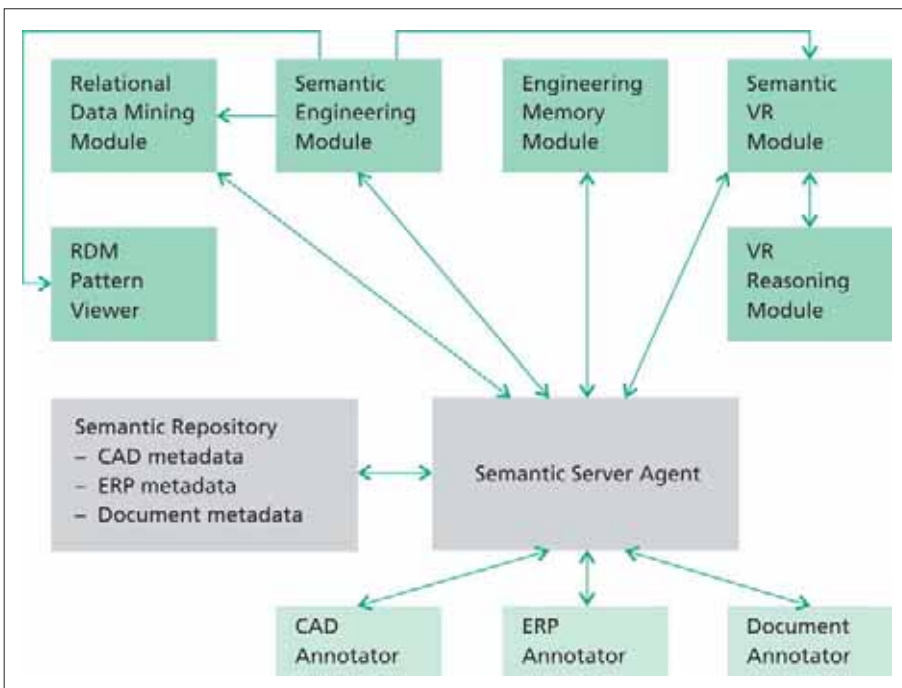

Fig. 2: Semantic engineering environment architecture.

Project Report from the
Central ViVERA Office

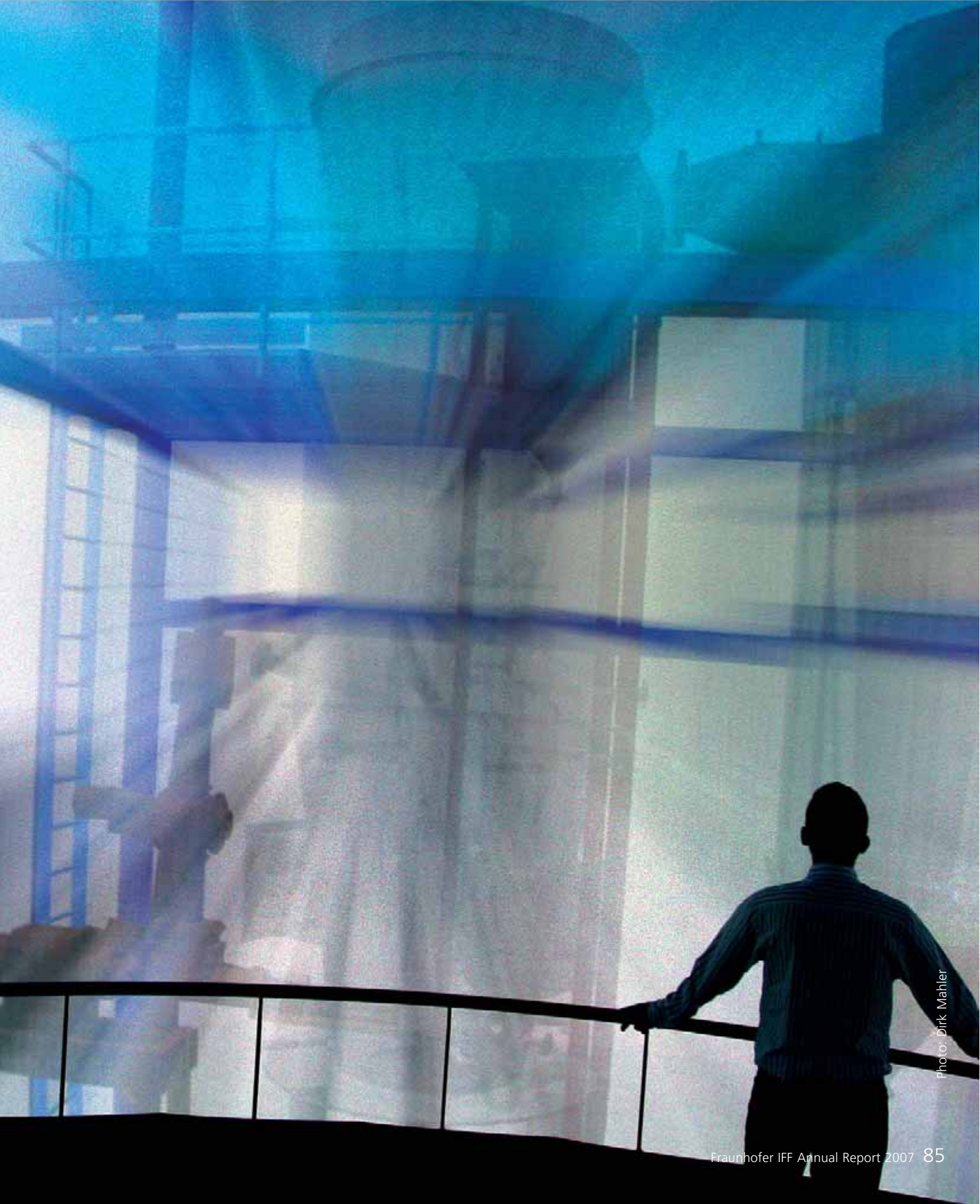

Photo: Dirk Mahler

ViVERA Network of Competence for Virtual and Augmented Reality

Marco Schumann
Tel. +49 391/40 90-158
Marco.Schumann@iff.fraunhofer.de

Motivation

ViVERA means "It lives!" in Portuguese. The vitality of the Network of Competence for Virtual and Augmented Reality supported by the Federal Ministry of Education and Research BMBF is demonstrated by the variety of activities carried out by the twelve allied Fraunhofer Institutes and universities. ViVERA's goal is to network existing competencies of VR and AR developers, identify further need for development, bundle developers and users' experiences, transfer their experiences to other fields of application and develop prototype demonstrators to do so. This will transfer research findings to corporate practice as rapidly as possible.

Approach and Results

The subprojects completed by the Fraunhofer IFF in the ViVERA consortium are focused on basic technologies and research and networking for specific fields of application. Basic technologies comprise self-contained VR functionalities

that can be used as the basis for development in the different fields of application. The Fraunhofer IFF has implemented two basic technologies. One basic technology, Model Generation for VR Applications, employs a new method to create virtual models, which is not only able to automatically capture geometry but also coloring (texture). The second basic technology developed at the Fraunhofer IFF, Interfaces to 3-D Model Generation Systems, allows importing and automatically postprocessing 3-D CAD models from commercial CAD systems.

Apart from developing basic technologies, ViVERA is also concentrating its work on topics for specific industries. The machinery and plant manufacturing, automotive, medical technology and shipbuilding industries are receiving special emphasis. The team of Fraunhofer IFF researchers in ViVERA is concentrating on the machinery and plant manufacturing sector. By fall of 2007, they had developed two demonstrators - one in machinery manufacturing and one in plant manufacturing. The demonstrators

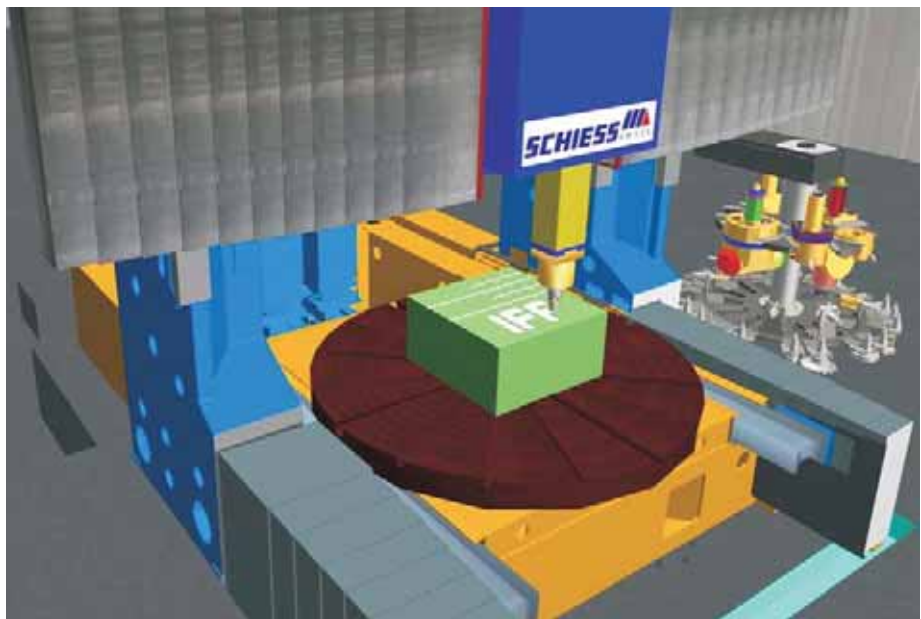

Fig 1: Virtual controller demonstrator.

The project is being supported by the Federal Ministry of Education and Research. (Reference No.: 01IRD01)

present typical industry applications of virtual technologies intended to convince enterprises to take advantage of these new technologies' potentials for themselves.

The Virtual Controller demonstrator was further developed in cooperation with SCHIESS GmbH and is now used by the manufacturer of heavy machinery to train equipment operators. The idea was to couple a real CNC with the virtual model of a heavy machine tool. This enables testing control programs at a time when the real machine is still being manufactured. Moreover, the combination of a real controller with the virtual model allows training operators in an extremely realistic environment.

The second demonstrator, Virtual Plant, implements the visualization of process engineering parameters, e.g. dynamic properties of temperature and pressure. In addition, sequences essential to the process are represented. At present, the optimization of the processes elapsing in several plant components is being

worked on. Simulation results from a flow simulation system (Fluent) are being employed. To ensure the components and their related models are interchangeable, a scheme to describe components and the simulations linked to them was worked on. Various forms of visualizing flow behavior are being validated. The flow visualization has been expanded to other component and variants of components with the intention of designing a visualization based on components, which will support the optimization of component visualization.

Another of ViVERA's basic concerns is cross-application networking of partners. The Fraunhofer IFF is pursuing two cooperations in particular. The experiences of a partner from Stuttgart were used for the VR Aided Engineering Workstation, which can be used both as a highly mobile and a stationary work system. The system provides a hitherto unachieved image quality, spontaneous stereo vision with comfortable stereo glasses and a largely maintenance-free tracking system. The flexible concept

allows extensive adaptation to a particular field of application. Along with CAD integration, training applications, medical engineering applications and support for large construction projects are conceivable. The reconfiguration of various functional units tested by the Fraunhofer IFF additionally allows using the system as a mobile 3-D stereo projection system, which has already been effectively employed at various events with SME and Saxony-Anhalt's Ministry of Economics and Labor. The second cooperation is related to the OpenSG visualization library and the Avalon application based upon it. Among other things, the software developed by the ViVERA partners in Darmstadt is used to present virtual environments in the Elbe Dom laser projection facility.

Collaboration

- Otto von Guericke University Magdeburg
- Fraunhofer IGD, Darmstadt
- Technical University of Darmstadt
- Fraunhofer IGD-R, Rostock
- University of Rostock
- Fraunhofer IPK, Berlin
- Technical University of Berlin
- Fraunhofer IWU, Chemnitz
- Technical University of Chemnitz
- Fraunhofer IAO, Stuttgart
- University of Stuttgart

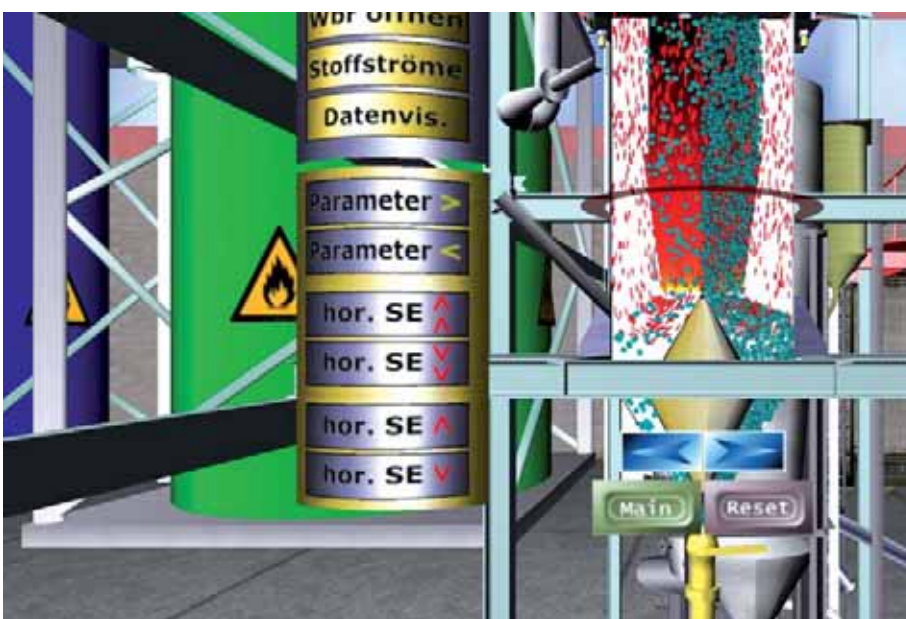

Fig. 2: Virtual plant demonstrator.

Project Reports from the
Process and Plant Engineering Business Unit

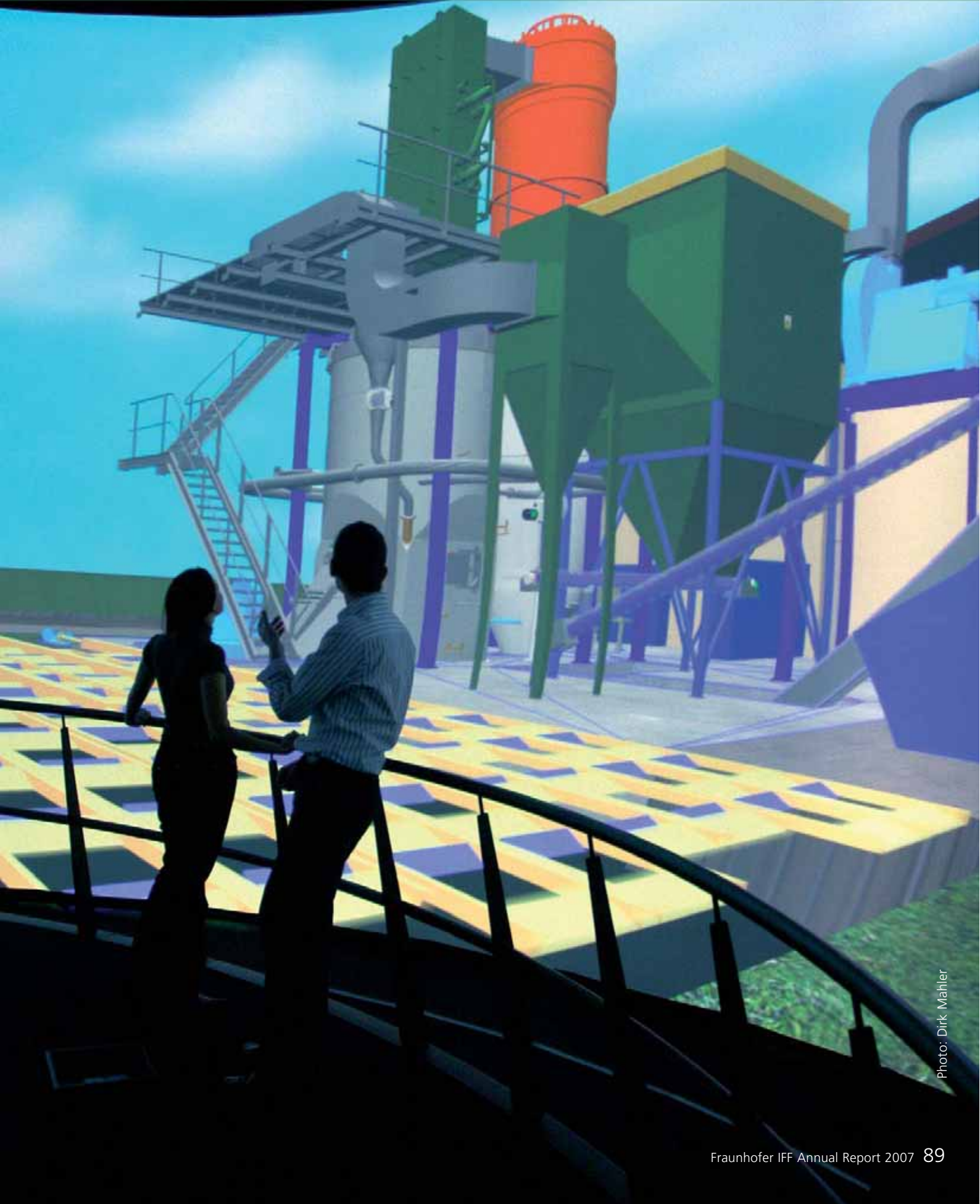

Photo: Dirk Mahler

Generating Virtual Interactive Scenarios to Visualize Process Equipment Process Parameters

Kathleen Otto
Tel. +49 391/40 90-338
Kathleen.Otto@iff.fraunhofer.de

Motivation

Developing new processes and plants that recover energy from biomass and calorific wastes not only necessitates experimental tests to assess the potential of a process principle or plant's cost effective utilization but also analyses supported by models. Chemophysical calculations, material balances and computerized flow simulations precisely analyze and project the sequence of material reactions inside a plant, thus allowing its optimization. Equipment is always designed by combining process simulation and engineering.

Increased computer performance and advances in computation have made three-dimensional flow simulation possible. In most cases, the enormous quantities of data produced can no longer be efficiently analyzed and evaluated since the simulation and CAD systems employed in process plant engineering are unable to represent the processes with any or only minimal interactivity. State-of-the-art is the presentation of simulation results on the basis of 2-D sections. Only experts are able to interpret such simulation results. New forms of visualization can solve this problem.

The solution is interactive tools combined with simulation and all the options of three-dimensional representation, e.g. geometry, illumination and textures. This makes new methods of representing process parameters and efficient processing into virtual interactive scenarios possible.

Approach

The objective was to further utilize and automatically merge existing product data, consisting of CAD and simulation data from processes, in order to be able to interpret it interactively. The intention was to flexibly represent process parameters of individual pieces of equipment including their flow behavior in space. Simultaneous visualization of geometric, engineering, process and parameter data was a priority of development. The suitability of metaphors from other domains of visualization to visualize this complex information was examined.

To achieve the objectives, the first step was to design the equipment being visualized and calculate the process parameters. Various types of simulation were applied to do this, e.g. chemical material balances and mathematical flow simulations. Generally, flows are processes that occur in the three dimensions of space and proceed variably (transiently) over time. However, mathematical treatment of these processes is too complex for the calculations usually applied. Hence, calculation usually involves the formulation of simplifying assumptions. In this case, the influence of time was disregarded. Thus, changes of the flow over time were not analyzed (steady-state conditions). A chemical material balance additionally simplifies the representation of space. This was only done one-dimensionally. Thus, it was only possible to analyze the processes along one axis.

This research project was supported by the Federal Ministry of Education and Research as part of the ViVERA Network of Competence.

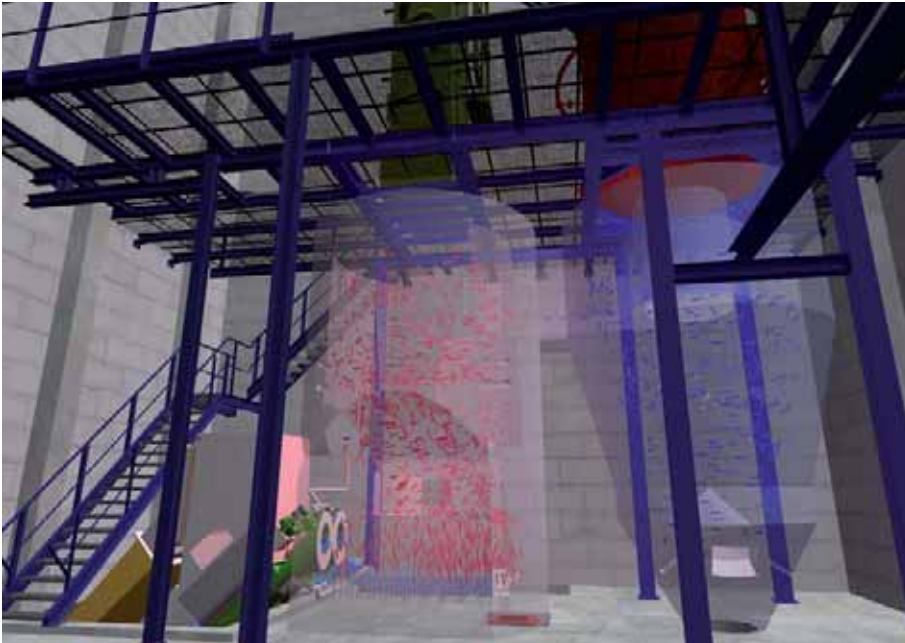

Fig.: A virtual interactive scenario generated with the developed solution.

Results

The concept was validated on a process plant that recovers energy from solid biomass such as wood. The outcome was an interactive VR scenario (pictured left) aimed at presenting geometric dimensions, operating principles and simulations of typical operation to clients before a plant is installed. Thus, a plant's construction and installation can already be discussed with clients while it is being engineered. Operator staff for the plant can be trained and typical operating conditions calculated with a model-based simulation can be presented. This makes it possible to virtually present the results from the various domains of virtual engineering in a complete visualization in real time.

Once the requisite product data was available, a solution that enables employing selectable sectional views to visualize process parameters such as temperature and pressure in space was developed in the next step. A concept to visualize materials flows, describing them with curves and subsequently representing them in virtual reality, had been developed in the first step. Thus, the concept does not utilize the simulation results and a flow is consequently approximated. Another disadvantage is that the concept cannot visualize any turbulence in three-dimensional space and the equipment visualized and its simulation data are not configured interchangeably, thus requiring additional development work for every new component.

Therefore, the visualization of the material flows was reworked in the second step and an algorithm to calculate flow paths was developed, optimized and implemented in preprocessing software. The algorithm was formulated so flexibly that various components can be used to calculate flow paths and virtual interactive scenarios can thus be generated automatically. Users can select various settings for a visualization, e.g. the number and particular type of objects visualized on a path, any time scale of the material flows and the number of paths displayed in the virtual scenario generated. Product data that accumulates during the designing of process equipment is employed. Thus, one or several pieces of process equipment can be described with the corresponding simulation results.

Integrated Process Systems to Recover Energy from Biomass in Fuel Cells

Dr. Sascha Thomas
Tel. +49 391/40 90-374
Sascha.Thomas@iff.fraunhofer.de

André Herrmann
Tel. +49 391/40 90-355
Andre.Herrmann@iff.fraunhofer.de

Dr. Eyck Schotte
Tel. +49 391/40 90-357
Eyck.Schotte@iff.fraunhofer.de

Motivation

One of humankind's greatest challenges is to avert a global climate catastrophe. That humans and not nature are responsible for global warming is beyond dispute and has been corroborated by the latest study from the United Nations' Intergovernmental Panel for Climate Change (IPCC). Unanimous agreement exists that, while climate change can no longer be stopped, its effects can and must be mitigated, i.e. made controllable. While they have already significantly picked up pace in recent years, efforts in the field of alternative energies will continue to increase tremendously in the years ahead.

One potential use of renewable energies is the gasification of biomass, which, when combined with fuel cell technology to recover energy from the generated fuel gas, holds great potential for sustainable and highly efficient generation of electrical energy. Given their high electrical efficiencies and ideal conditions for

cogeneration, low noise levels and low emissions, fuel cells will likely be accorded greater importance for the distributed supply of power in the future. Moreover, the use of renewable materials as the source material for fuel gas generation will increase independence from nations exporting fossil fuels, thus enhancing the security of the energy supply and ensuring the energy generated emits little CO₂ and is environmentally compatible.

Objective and Division of Work

Both the Max Planck Institute for Dynamics of Complex Technical Systems and the Fraunhofer Institute for Factory Operation and Automation IFF in Magdeburg and the Fraunhofer Institute for Ceramic Technologies and Systems IKTS in Dresden are collaborating on the project ProBio to develop and engineer a system consisting of a gasification unit to generate fuel gas, cleaning stages to process it and high and low temperature fuel cells to utilize it. Both experimental studies to

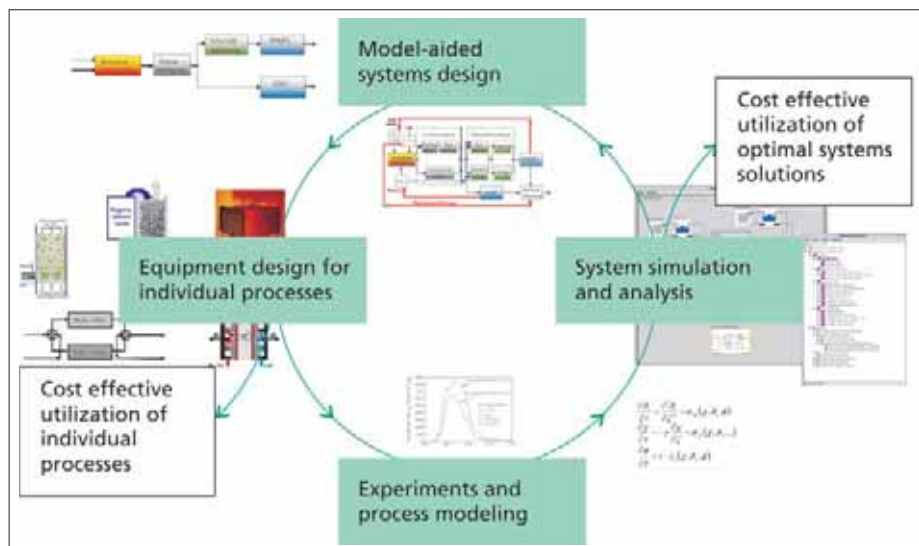

Fig. 1: Development cycle of the complete system engineered to recover energy from biomass in fuel cells.

This project is being financed with supplementary funds from the Federal Ministry of Education and Research's research community "Pact for Research and Innovation".

test the process steps integrated in the planned overall system and theoretical studies of the optimal interconnection of the individual processes have been planned. The closely collaborating project partners intend to incorporate their experimental findings to simulate individual system components and the coupling of their material and energy within the overall system in models.

Given its expertise in the thermochemical conversion of organic materials, the Fraunhofer IFF is primarily working on the generation of fuel gas from biomass by means of fluidized bed gasification as well as on tests of primary gas cleaning and conditioning. New reactor concepts will be applied, e.g. a walking bed reactor for combined removal of dust and tar and other cleaning stages for the removal of sulfur and halogen compounds. The Max Planck Institute will be in charge of experimentally testing secondary gas cleaning and ultrapurification with a cyclic iron oxide redox process, electrochemical CO oxidation and dynamics of PEMFC single cells and stacks..

The Max Planck MPI will also perform the model-based analysis of the material and energy flows in the individual process steps, clarify the stationary and dynamic interactions of individual processes in the overall system and optimize the system. In close cooperation with the Fraunhofer IFF and the Fraunhofer IKTS, the Max Planck researchers will model the biomass gasifier stage, the primary cleaning stage and the SOFC.

Experts in ceramic materials, the Fraunhofer IKTS will fabricate spherical catalyst supports from abrasion resistant material for use in the Fraunhofer IFF's walking bed reactor. In addition, the Fraunhofer IKTS will produce the SOFC single cells and stacks and take measurements to characterize them. The Fraunhofer IKTS will synthetically compose the fuel gases generated by gasification and measured at the Fraunhofer IFF and test their use in SOFC stacks.

Particular attention will be paid to the effect of pollutant gas components, e.g. hydrogen sulfide, or tar components in the wood gas on the fuel cells' long-time operation.

Outlook

The ProBio project has initially been scheduled for three years and is intended to serve as the start phase for longer range strategic collaboration between the three institutes involved. Should the evaluation at the end of this first phase be positive, a three-year extension will follow, during which time the theoretical and experimental findings acquired will be applied to construct and operate a pilot system. The three institutes would then share the responsibility of erecting and operating this pilot system in Magdeburg.



Fig. 2: Low temperature fuel cell stack demonstrator (PEMFC).
Photo: Peter Förster

Project Partners

- Max Planck Institute for Dynamics of Complex Technical Systems MPI, Magdeburg
- Fraunhofer Institute for Ceramic Technologies and Systems IKTS, Dresden

Development of a Compact Fluidized Bed Firing Plant for Low-emission Combustion of Biomass

Dr. Matthias Gohla
Tel. +49 (0) 391/40 90-361
Matthias.Gohla@iff.fraunhofer.de

Motivation

The Fraunhofer IFF develops plants that employ combustion and gasification technologies to utilize regenerative energy sources such as biomass and biogenic wastes.

The oldest and easiest method to recover energy from biomass is firing. To guarantee complete and low-emission combustion and allow for ash content and fuel composition, form and particle size, different firing types have been developed for different size classes of plants. The basic difference is the fuel preparation and feed and the type of combustion chamber.

For reasons of availability and development, combustion grates enjoy widespread use as a firing technology for fossil and biomass powered plants. However, the mechanical moving parts in the temperature loaded combustion chamber, the relatively uneven grate charging and thus the erratic temperature profiles throughout the free space cross section are disadvantages of grate firing. The uneven charging and thus

irregular airflow through the free grate cross section results in relatively uneven combustion and the appearance of gas strands in unburned carbon monoxide and hydrocarbons.

To eliminate these disadvantages, firing technologies have to be selected, which allow intensive gas-solid contact and uniform fuel charging of the combustion chamber. Pulverized coal firing establishes excellent contact between the oxygen supplier air and the solid fuel, yet the fuel preparation requires a great deal of technological complexity, i.e. it requires mechanical reduction of the solid fuel down to particle fractions < 1 millimeter. Given their relatively low solid density, the high volumetric flows of fuel and especially biomass usually render such fuel processing not cost effective.

The fluidized bed is a technological alternative to pulverized coal firing with high gas-solid contact and uniform fuel mixing. Its use of a broad range of fuels is an additional advantage.

Combustion chamber temperatures of 850 to 950 °C are common in fluidized

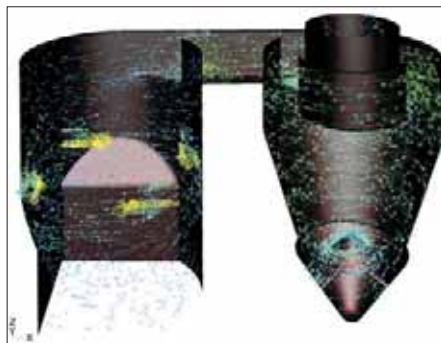

Fig. 1: Vectorial representation of the flow velocity from a Fluent® flow simulation of the firing plant.



Fig 2: Steelwork for the firing plant.
Photo: Matthias Gohla

beds. This prevents the formation of thermal nitrogen oxides and slagging, especially when biofuels have low ash fusion points. Thus the fluidized bed is an advantageous alternative to grate and pulverized coal firing. However, it has not yet been used in the thermal output range of 1 to 10 megawatts.

Conceptual Solution

A fluidized bed firing plant has been developed for this range. It was laid out and engineered according to the demanding power data specifications and space and investment requirements of a comparable grate firing plant produced by Kohlbach Wolfsberg in Austria, one of the market leaders in biomass grate firing plants. The grate firing plant's volumetric raster served as the basis for a target parameter and the process engineering design was correspondingly adapted to design the plant compactly. The main components of the firing plant are a fluidized bed with free space and a combustion cyclone.

A three-dimensional simulation model was created to validate the plant's general mode of operation and ensure the flue gases have a sufficient residence time in the plant. Thus, by varying the primary, secondary and tertiary volumetric air flows, the volumetric flow of flue gas recirculation and the connected plant output, the fluid mechanics expected in the plant can be visualized and its function can be analyzed for the widest variety of operating points. Fig. 1 presents the results of such a calculation.

The firing plant consists of an external steel shell, finished on the inside with a multilayer insulating and refractory lining that simultaneously protects against wear. Fig. 2 shows the assembly of a compact 4 megawatt class plant, specifically the biomass cogeneration plant for the Bodelschwingh-Haus in Wolmirstedt. The plant is completed by a fuel oil powered pilot burner system to control the warm-up and start of the plant.

Results

The first results of plant operation have exhibited optimum fuel burn-off and the analyzed ash samples from combustion cyclone discharge have a residual carbon content of 0.1 percent by mass. The fly ash sampled in the discharge in the flue gas dedusting unit after the firing plant has a residual carbon content of around 2 percent by mass, well below the technical directive for residential waste. Another value that describes the firing plants performance is the carbon monoxide concentration in the flue gas. It was measured below the minimum quantity detectable by the measuring instrument. The concentration of nitrogen oxides in the flue gas is 120 to 130 mg/Nm³ and thus, at approximately 40 percent, well below both the legal limit and a comparable grate firing plant's emission value.

The three-dimensional conceptual drawing in Fig. 3 pictures the compactly constructed firing and boiler plant produced together with Kohlbach Cogeneration und Bioenergie GmbH for the biomass cogeneration plant project for the Bodelschwingh-Haus Wolmirstedt.



Fig. 3: 3-D representation of the firing plant (gray) with thermal oil boiler (red) and economizers (green).

Project Partners

- Kohlbach Cogeneration und Bioenergie GmbH
- Biomasse-Heizkraftwerk Bodelschwingh-Haus Wolmirstedt

Highlights, Events and Trade Fair Presentations in 2007
(Selection)



Photo: Viktoria Kühne



A picture is worth more than a thousand words:
 A virtual interactive training scenario for pilot training developed for
 Lufthansa Flight GmbH was presented at the Learntec trade show.
 Photo: Viktoria Kühne

February 2, 2007, Magdeburg

Bestpractice LSA

Presentations:

- Virtual Technologies: Regional Competence and Services for Small and Medium-sized Enterprises
- Long-lived Devices as an Example of Qualification in a Virtual Environment
- Applications for Small and Medium-sized Enterprises from the ViVERA Network of Competence

Direction:

Prof. Michael Schenk

Contributors:

Marco Schumann

Heike Kissner

February 13 - 15, 2007, Karlsruhe

Learntec 2007 (Congress)

Exhibit:

- Virtual Interactive Training Scenario for Pilot Training

Contributors:

Heike Kissner

Wilhelm Termath

Waleed Salem

February 13 - 15, 2007, Stuttgart

International Trade Fair for Distribution, Materials Handling and Information Flow
 LogiMat 2007

Exhibits:

- IFF Smart Box
- RFID Order Picking Table

Contributors:

Helmut Röben

Sven-Uwe Hofmeister

Eyk Flechtner

February 15, 2007, Magdeburg

DJV Press Seminar: Virtual Reality in Research and Media

Host:

Deutscher Journalisten Verband DJV,
Fraunhofer IFF

Contributors:

Prof. Michael Schenk

Anna-Kristina Wassilew

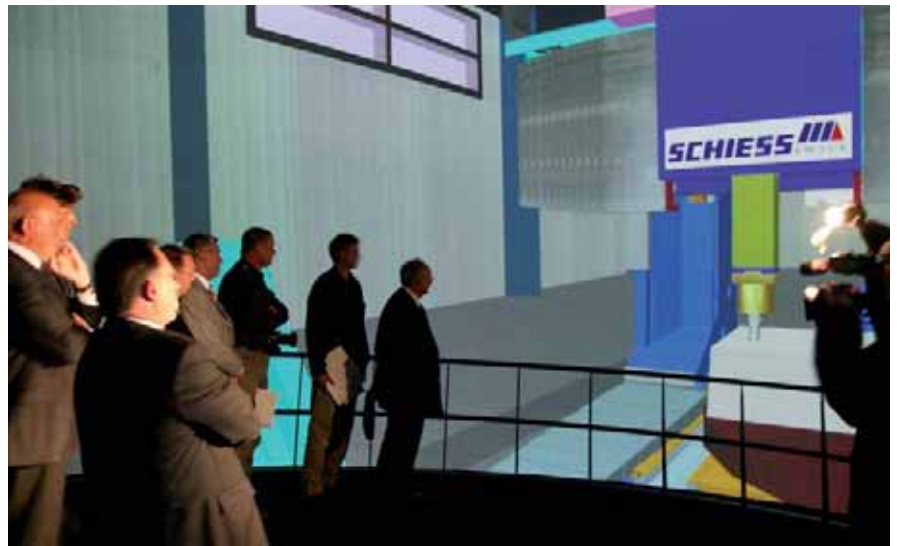

A seminar for journalists emphasized the treatment of scientific topics. As a research institute, the Fraunhofer IFF was the perfect partner for the workshop. Photo: Viktoria Kühne

February 21, 2007, Magdeburg

RFID Aided Construction Site Logistics (Workshop)

Host:

Fraunhofer IFF

Presentations:

- Radio Technologies Are Conquering Logistics Assets
- RFID Aided Construction Site Logistics: Project Objectives, Approach and Results
- Transfer of Goods and Material Management Secured by RFID at Construction Sites
- Localization Technologies at Construction Sites

Direction:

Prof. Michael Schenk

Cathrin Plate

Dr. Klaus Richter

Tobias Kutzner

Bernd Gebert

Andre Hanisch



RFID transponders are wireless helpers in state-of-the-art logistics. They are outstandingly suited for systematic use in construction site logistics. Taking the research project "RFID Aided Construction Site Logistics" as an example, a workshop highlighted experiences with and results of applications with RFID technology in small and medium-sized enterprises.

Photo: Dirk Mahler

February 22 - 23, 2007, Magdeburg

b2d-Business To Dialog

Exhibit:

- One Step Services

Contributors:

Jörg von Garrel

Holger Seidel

The Gesellschaft für Arbeitswissenschaft held its 53rd spring convention in Magdeburg from February 28 to March 2, 2007. Themed "Developing Competence in Real and Virtual Work Systems", the convention provided an overview of the latest state of technological development and research findings. In addition, it stimulated an active exchange of knowledge.



Prof. Klaus Jenewein from the Department of Vocational Education and Human Resources Development at Otto von Guericke University Magdeburg.
Photo: Otto von Guericke University Magdeburg



This professional forum aimed to bring together actors throughout the value added chain for new products, for the manufacturing of which various applications of electron beam technology can be efficiently employed. The Fraunhofer IFF is a cooperation partner of the Innovationsforums Elektronenstrahltechnologie. At the end of the forum, the Fraunhofer IFF offered all attendees an excursion to its newly opened Virtual Development and Training Centre VDTC.

February 28 - March 2, 2007, Magdeburg

53rd Spring Convention of the Gesellschaft für Arbeitswissenschaft

Host:

Fraunhofer IFF, Otto von Guericke University Magdeburg, GTW Bremen

Presentations:

- Reality and Virtuality in Competence Development Processes: The State of Media Science Research
- State and Development Trends of the Use of VR/VA Technologies for Qualification and Training in the Work Process
- Process Plants as an Example of Qualification and Competence Development as an Integral Part of Advanced Product Service Strategies
- Didactic Potentials of Learning with Interactive VR Systems Represented by Maintenance Staff Training with a Virtual System of an Airbus A320
- A Comfort Construct as Part of a Load-Stress Concept

Contributors:

Prof. Michael Schenk
Dr. Eberhard Blümel
Wilhelm Termath
Dr. Rüdiger Mecke
Dr. Martin Endig
Dr. Matthias Gohla
Frank Mewes
Torsten Schulz
Marianna Ackermann

March 7 - 8, 2007, Burg

Innovation Forum of Electron Beam Technology in Machinery and Process Equipment Manufacturing

Host:

Technologie- und Gründerzentrum Jerichower Land GmbH

Presentation:

- Utilizing Virtual Environments to Qualify Personnel to Handle Complex Technical Systems

Contributor:

Prof. Michael Schenk
Andrea Urbansky

March 8, 2007, Magdeburg

Best4City Agreement Signing

Contributors:

Prof. Michael Schenk

Dr. Klaus Richter

Corinna Kunert

March 8 - 9, 2007, Magdeburg

Simulation and Visualization 2007 (SimVis), (Conference): Forum for Military, Government, Research and Industry Representatives Interested in the Research Fields of Visualization and Simulation

Host:

Department of Simulation and Graphis (ISG), Otto von Guericke University Magdeburg

Presentations:

- Modeling and Manipulating Deformable Hose-like Objects in a Virtual Reality Environment
- Coupling CNC and Virtual Models

Contributors:

Prof. Michael Schenk

Wolfram Schoor

Dr. Rüdiger Mecke

Marco Schumann

Torsten Böhme

March 12, 2007, Magdeburg

ProBio Research Project Start

Contributors:

Prof. Michael Schenk

Dr. Lutz Hoyer

Dr. Sascha Thomas

March 14 - 16, 2007, Leipzig

Z2007 Subcontracting Fair

Host: Leipziger Messe GmbH

Exhibits:

- Immersive Engineering Workstation
- VDTC Services for Small and Medium-sized Enterprises

Contributors:

Ronny Franke

Armin Wagner

The project Best4City aims to ease urban traffic in Germany. To this end, the contribution of IT based, organizational and technical measures of a concept for new interchangeable trailers for vehicles to a more urban-friendly organization commercial traffic is being researched.



Once the agreement has been signed at the Saxony-Anhalt Ministry of State Development and Transportation, project manager Klaus Richter (3rd from l.) and Director Michael Schenk (5th from l.) explained to Minister of State Development and Transportation Karl-Heinz Daehre (6th from l.) and his colleagues how interchangeable trailers function in practice.

Photo: Herbert Siegert

Fuel cells are predominantly powered by hydrogen. Biomass rather than fossil fuels will be increasingly be used as feedstock in the future. In the new research project "ProBio", researchers from Magdeburg and Dresden are researching the effective and environmentally compatible use of renewable raw materials to generate electricity. The Fraunhofer IFF, Fraunhofer IKTS and Max Planck Institute for Dynamics of Complex Technical Systems hosted a joint press conference to officially kick off the project.



L. to r.: Prof. Alexander Michaelis, Director of the Fraunhofer IKTS in Dresden; Prof. Kai Sundmacher, Director of the MPI in Magdeburg; Prof. Michael Schenk, Director of the Fraunhofer IFF in Magdeburg.

Photo: Peter Förster

The Fraunhofer IFF presented new logistics solutions for secure chains of goods at CeBIT. Above all, technological solutions for RFID, telematic and satellite navigation were presented to the professional public. At the Forum for Telematics and Navigation during CeBIT 2007, Lower Saxony Minister of Economics, Labor and Transportation Walter Hirche and Saxony-Anhalt Minister of State Development and Transportation Karl-Heinz Daehre spoke about the two states' cooperation on the satellite navigation system Galileo. Daehre mentioned the research project Best4City with the Fraunhofer IFF integrated in the state initiative Galileo Transport in Saxony-Anhalt as the first concrete project of the states' cooperation.

L. to r.: Harry Evers, Managing Director of GZVB Competence Center GmbH/GAUSS; Walter Hirche, Lower Saxony Minister of Economics, Labor and Transportation; Dr. Karl-Heinz Daehre, Saxony-Anhalt Minister of State Development and Transportation; Prof. Michael Schenk, Director of the Fraunhofer IFF; Dr. Klaus Richter, Expert Group Manager at the Fraunhofer IFF.
Photo: Herbert Siegert



Deutsche Post World Net opened its future lab DHL Innovation Center in Troisdorf near Bonn. The DHL Innovation Center's aim and work is to develop new, marketable products with a high level of innovation from future logistics trends. Also on board is a development from the Fraunhofer IFF in Magdeburg. Together with Deutsche Post World Net, the research institute developed the IFF Smart Box, an intelligent carrier that facilitates running inventory, registers and documents every loaded and unloaded package and is localizable worldwide through different radio technologies.

Photo: Deutsche Post World Net

March 15, 2007, Magdeburg

Technical Innovations for Small and Medium-sized Enterprises

Host: Bundesverband Mittelständische Wirtschaft, Fraunhofer IFF, Network KMU (Workshop)

Presentation:

– Research for the Real World

Contributors:

Prof. Michael Schenk

March 15 - 21, 2007, Hannover

CeBIT 2007 (Trade Fair)

Host: Deutsche Messe AG

Exhibits:

– RFID Glove

– UHF Smart Box

Contributors:

Prof. Michael Schenk

Dr. Klaus Richter

Corinna Kunert

Bernd Gebert

March 16 - 20, 2007, Hannover

Hannover Messe

Host: Deutsche Messe AG

Exhibits:

– Testt Vehicle with Interchangeable Trailer for RFID Applications

Contributors:

Helmut Röben

Katrin Reschwamm

March 27, 2007, Bonn

DHL Innovation Center Opening

Exhibit:

– Transporters with Interchangeable Trailers

– IFF Smart Box

Contributors:

Dr. Klaus Richter

During a visit to the Fraunhofer IFF VDT, Federal Minister of Finance Peer Steinbrück was informed about research work at the Fraunhofer IFF. Director Michael Schenk and Deputy Director Gerhard Müller explained the virtual reality specialists' current research projects to Steinbrück. The Minister of Finance listened to an explanation of the Elbe Dom and visited other labs for the fields of virtual reality and process and plant engineering. Afterward, the minister spoke there with representatives from business and research. Steinbrück took advantage of his informal visit to get a picture of business and research in Magdeburg in rounds of discussion.

April 17, 2007, Magdeburg

Visit from Federal Minister of Finance
Peer Steinbrück
Contributors:
Prof. Michael Schenk
Dr. Gerhard Müller

April 17 - 18, 2007, Hannover

Cooperation Exchange + b2fair
Matchmaking Event
Host:
IRC Network in Cooperation with the
Fraunhofer IFF
Main Topic:
– Automated Solutions for SME:
smE-MPOWER
Contributors:
Katrin Reschwamm



L. to r.: Prof. Michael Schenk, Director of the Fraunhofer IFF, Peer Steinbrück, Federal Minister of Finance, Dr. Gerhard Müller, Deputy Director of the Fraunhofer IFF. Photo: BMF

April 17 - June 19, 2007, Magdeburg

10th Guest Lecture Series: Logistics as a
Field of Work of the Future: Potentials,
Implementation Strategies and Visions
Host:
Fraunhofer IFF
Direction:
Prof. Michael Schenk, Fraunhofer IFF
Prof. Karl Inderfurth, School of
Management, Department of Production
and Logistics, Otto von Guericke
University Magdeburg
Prof. Dietrich Ziems, Chair of Logistics,
Otto von Guericke University Magdeburg
Patronage:
Dr. Karl-Heinz Daehre, Saxony-Anhalt
Minister of State Development and
Transportation



As its patron, Saxony-Anhalt Minister of State Development and Transportation Karl-Heinz Daehre opened the Guest Lecture Series with welcoming remarks.
Photo: Anna-Kristina Wassilew

With 2.6 million jobs, logistics has become the third largest industry in Germany and had record sales of 166 billion euros in 2006. The industry is booming in Saxony-Anhalt too: "Central Germany has evolved into one of the most important centers of logistics in all of Europe", confirmed Minister of State Development and Transportation Karl-Heinz Daehre at the opening of the Guest Lecture Series. With top speakers from the field, the Guest Lecture Series gives attendees first hand insight into corporate thought and action.



Landesforstbetrieb Sachsen-Anhalt and the Fraunhofer Institute for Factory Operation and Automation IFF extended a joint invitation as part of a series of events on wood logistics in spring of 2007. Saxony-Anhalt Minister of Agriculture and the Environment Petra Wernicke (left) opened this road show. The main focus of this practically oriented event was the entire supply chain from the forest to the factory. Presentations (right) highlighted logistics solutions for the wood processing industry: Timber accounting, deck management, fleet management and an off-road navigation system organize operations more efficiently and cut costs. Field demonstrations particularly met with great interest among audiences.
Photos: Viktoria Kühne

Over 120 Russian and German attendees who took part in the intensive exchange of experiences made this event a complete success. Predominantly developers, users, service providers and end customers from the aviation, automotive and transportation industries attended the conference to establish contacts, exchange new ideas and initiate new projects.



Interlogistica addresses aspects of reliability and quality in the logistics industry.
Photo: GosNIIAS

April 18, 2007, Hundisburg

Wood Logistic: Implementing Practicable Solutions

Host:

Fraunhofer IFF, Landesforstbetrieb Saxony-Anhalt

Exhibits:

- Offroad-Navigation
- Software for Tour Management

Contributors:

Prof. Michael Schenk

Dr. Ina Ehrhardt

Holger Seidel

Maik Wäsche

Daniel Reh

Corinna Kunert

April 25 - 26, 2007, Moscow (Russia)

Interlogistica: International Conference on Logistics Processes in the Aviation, Automotive and Transportation Sectors: Quality and Reliability

Host:

Fraunhofer IFF on behalf of the Interlogistica Consortium in cooperation with the German Logistics Association BVL

Patron: Russian Ministry of Transportation (MinTRANS) and Russian Federal Agency for Industry (ROSPROM)

Presentation:

- Secure Chains of Goods Prerequisite to International Cooperation

Contributors:

Prof. Michael Schenk

Dr. Ulrich Schmucker

Holger Seidel

Helmut Röben

Dr. Stanislav Morozov

Sergej Serebranski

Andreas Mähnz

May 8 - 11, 2007, Sinsheim

Control (Trade Fair)

Host: Messe Sinsheim GmbH

Exhibits:

- Optical 3-D Measuring System for Industrial Quality Inspection
- Model-based Optical Assembly Assistance

Contributors:

Ralf Warnemünde

Dr. Christian Teutsch

May 10, 2007, Wernigerode

European Innovation Support: New Opportunities for SME (Workshop)

Host: District of Wernigerode, Agency for Economic Development in cooperation with the Fraunhofer IFF

Presentations:

- European Research Support: The 7th Research Framework Programme, Opportunities for Small and Medium-sized Enterprises to Participate
- smE-MPOWER: European Innovation Support, New Opportunities for SME

Contributors:

Katrin Reschwamm

Marco Schumann

May 14 - 18, 2007, Hannover

Ligna Hannover 2007 (Trade Fair)

Host: Deutsche Messe AG

Exhibits:

- Off-road Navigation
- Software for Route Management
- Recovery of Energy from Biomass

Contributors:

Dr. Ina Ehrhardt

Maik Wäsche

Tobias Kutzler

Dr. Roman Bystritzky



An optical 3-D measuring system inspects wheelset quality.
Photo: Anna-Kristina Wassilew

The Fraunhofer IFF presented "IT Solutions for Web-supported Systems for Reliable Supply Chains from the Forest to the Factory by Using Mobile Off-road Navigation" (picture) and the "Design, Development and Construction of Complete Plants to Recover Energy from Biomass on the Basis of Fluidized Bed Technology".



Use of the off-road navigation systems from the Fraunhofer IFF in the field.
Photo: Viktoria Kühne

Magdeburg wants to know: With a record 10,000 visitors, the Second Long Night of Science repeated the success of 2006 and demonstrated that the idea to bring inquisitive individuals together with experts functions superbly. Science fans were able to visit 15 locations with 135 presentations in 2007.

Many interested visitors began their tour at the VDTC, the cutting-edge training center for virtual technologies. In the Elbe Dom with its 360° large projection surface, they traveled through the virtual Lutherstadt Eisleben and flew from the marketplace through alleyways to the tip of the church steeple. Visitors were also able to look over researchers' shoulders in the main Fraunhofer IFF building on Sandtorstrasse and find out about the research organization's new and interesting projects in the fields of robotics, measurement and testing technology and logistics on a tour of the Fraunhofer IFF's testing facility.



Bustling activity in front of the VDTC on the occasion of the Long Night of Science.
Photo: Viktoria Kühne

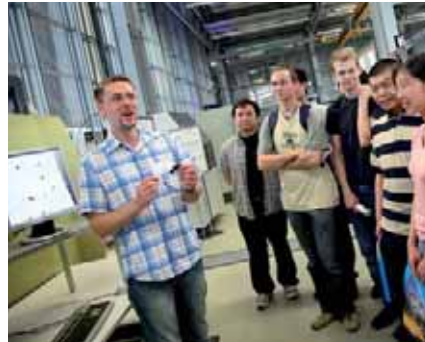

Christian Teutsch (left) explains optical 3-D metrology.
Photo: Viktoria Kühne



Dr. Eyk Schotte (right) leads visitors through the lab of the Process and Plant Engineering Business Unit.
Photo: Viktoria Kühne

June 12 - 15, 2007, Munich
transport logistics 2007 (Trade Fair)

Host: Messe München GmbH

Exhibit:

- Strategisc and Tactical Supply Chain Planning

Contributors:

Daniel Reh

June 13, 2007, Halle

2nd Consolidation and Growth Trade Fair

Host:

NETWORK-KMU State Initiative

Exhibit:

- smE-MPOWER

Contributors:

Katrin Reschwamm

June 14 - 15, 2007, Paderborn

Augmented and Virtual Reality in Product Development (Workshop)

Presentation:

- See-through Calibration for Mobile Augmented Reality Assistant Systems

Contributors:

Johannes Tümler

Dr. Rüdiger Mecke

Jian Xu

June 16, 2007, Magdeburg

Long Night of Science

Host: Capital City Magdeburg

Contributors:

Approx. 80 Fraunhofer IFF Employees

June 19 - 20, 2007, Stuttgart

28th VDI/VDEh VDI/VDEh Maintenance Forum 2007

Maintenance under Scrutiny (Congress)

Host:

VDI-Wissensforum IWB GmbH

Presentation:

- Radio Frequency Identification in MAintenance

Contributors:

Dr. Gerhard Müller

Cathrin Plate

The Maintenance Forum aimed at reviewing the situation of maintenance in the context of global competition and the eastward expansion of the domestic European market. Maintenance can become a crucial competitive advantage if it manages to competently respond to technology and systems' formidable innovative leaps in the future too. Presentations and discussions identified current trends and future requirements for employee qualification, which will define the technical equipment and organization of maintenance and the layout of a "knowledge organization".

June 27 - 29, 2007, Magdeburg

10th IFF Science Days "Logistics: Intelligence in Manufacturing and Transportation" and "Virtual Reality and Augmented Reality for Engineering, Testing and Operating Technical Systems"

Direction:

Prof. Michael Schenk

Program

June 27, 2007

- Welcoming Remarks and Impulse Lectures
- Sequence 1
Logistics Intelligence in Manufacturing and Transportation

Infrastructures for Intelligent Logistics

Moderation:

Dr. Klaus Richter

Logistics in Intelligenten Manufacturing

Moderation:

Dr. Hartmut Zadek

Innovation in Transportation

Moderation:

Harry Evers



For over ten years, executives, developers and users have been gathering at conferences, workshops and industry seminars to find out about and exchange views on the latest trends and developments. They jointly develop new ideas and successfully initiate projects here. Two international professional conferences were held as part of the

10th IFF Science Days. The conference on "Logistics: Intelligence in Manufacturing and Transportation" took up a key research specialization of the Fraunhofer IFF. Resuming the direction of preceding years, there was a conference entitled "Virtual Reality and Augmented Reality for Engineering, Testing and Operating Technical Systems" in 2007. The newly opened Virtual Development and Training Centre VDTc was integrated in the Science Days for the first time and its various VR and AR labs made it possible to experience virtual technologies in the field.



IFF Science Days patron, Minister of Economics and Labor Haseloff speaking at the opening of the professional conference "Virtual Reality and Augmented Reality for Engineering, Testing and Operating Technical Systems". Photo: Viktoria Kühne

“Present and Future Robot Engineering” was the topic of the presentation delivered by Prof. Peter Kopacek from the University of Vienna. Photo: Viktoria Kühne



In his impulse lecture, Michael Reinboth from DHL Hub Leipzig GmbH spoke on Central Germany's future prospects as a center of logistics. Photo: Viktoria Kühne



The Virtual Engineering Strategy Group met during the IFF Science Days. Photo: Viktoria Kühne



The evening event in the festive atmosphere at Magdeburg's Technikmuseum . Photo: Viktoria Kühne

– Sequence 2
Virtual Reality and Augmented Reality for Engineering, Testing and Operating Technical Systems

Virtual Engineering
Moderation:
Dr. Ulrich Schmucker
Innovative Development Trends in VR/AR Technology
Moderation:
Dr. Eberhard Blümel

June 28, 2007

– Sequence 2
Virtual Reality and Augmented Reality for Engineering, Testing and Operating Technical Systems

Technology-based Qualification
Moderation:
Prof. Klaus Jenewein
Assoc. Prof. Michael Dick

Digital Factory
Moderation:
Dr. Gerhard Müller
Prof. Bernhard Karpuschewski

Medical Technology
Moderation:
Asst. Prof. Matthias Pross

Innovative Development Trends in VR/AR-Technology
Moderation:
Prof. Karl-Heinrich Grote

Virtual Engineering
Moderation:
Prof. Roland Kasper
Prof. Ulrich Gabbert

Additional Workshops/Events

- Industry Working Group:
Cooperation in Plant Engineering
Moderation:
Andrea Urbansky
- Workshop:
Robot Technologies for Use in
Everyday Environments
Moderation:
Dr. Norbert Elkmann
- Working Meetings:
One Stop Services
Moderation:
Jörg von Garrel
- Statellogger
Moderation:
Frank Ryll
- RFID
Moderation:
Cathrin Plate

Moscow State Automobile and Road Technical University MADI awarded Prof. Michael Schenk an honorary doctorate in the festive setting of the evening event of the 10th IFF Science Day during which the institute simultaneously celebrated its fifteenth anniversary. MADI Rector Prof. Vjacheslav Prikhodko traveled to Magdeburg just for this occasion and conferred the title of Honorary Doctor of Technical Sciences on the logistics expert during the festivities.



MADI Rector Prof. Vjacheslav Prikhodko (left) awarded Fraunhofer Director Michael Schenk (center) an honorary doctorate from Moscow State Automobile and Road Technical University. To the right: Dr. Frank Wende. Photo: Viktoria Kühne

Deputy Director Gerhard Müller was also gratified by an award on this evening. Director and Executive Member of the VDI Board, Dr. Willi Fuchs surprised him with the VDI medal of honor "for outstanding service and the cultivation of young engineers by involving them in collaboration between applied research and industry in the pioneering fields of logistics and power engineering."



Director and Executive Member of the VDI Board, Dr. Willi Fuchs (right) presents Dr. Gerhard Müller (left) his award. Photo: Viktoria Kühne

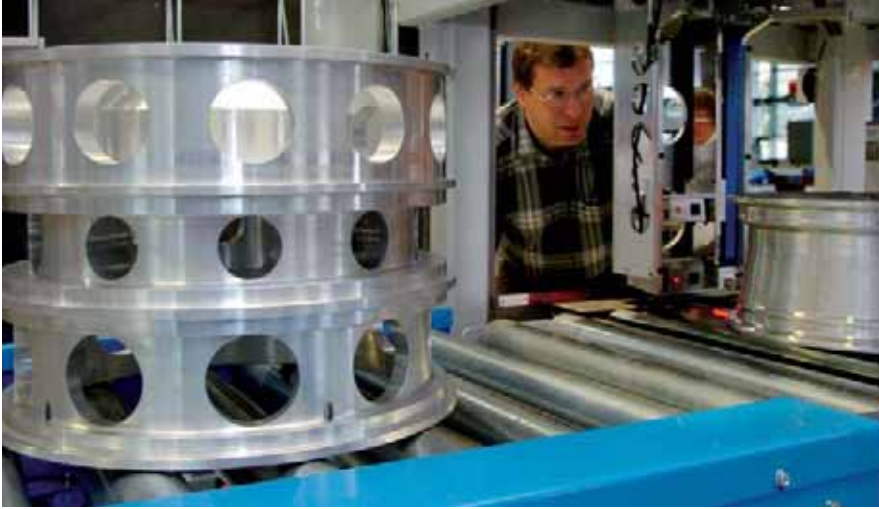

Optical 3-D measuring systems inspect the quality of vehicle rims.
Photo: Viktoria Kühne

At the Power Plant Forum, the Fraunhofer Institute for Factory Operation and Automation IFF in Magdeburg and TÜV Rheinland Industrie Service GmbH concluded a cooperation agreement to collaborate intensively. The Fraunhofer IFF will contribute its technical know-how in process and plant engineering, condition monitoring of technical assets and IT to the new partnership. TÜV Rheinland rounds out the portfolio with practical methods and tools for condition-based maintenance and inspection extension based on its experiences with large-scale power plants.



At the Power Plant Forum, Michael Oelkers, Head of TÜV Rheinland's Supply and Disposal Division (center), and Dr. Gerhard Müller, Deputy Director of the Fraunhofer IFF (right) agreed to collaborate intensively.
Photo: Viktoria Kühne

June 28, 2007, Jena

Seminar with Practical Training: Optical 3-D Metrology for Quality Assurance in Production

Host:

Fraunhofer "Vision" Alliance, Fraunhofer IFF

Presentation:

- Flexible Geometry Inspection of Workpieces by Applying Optical Measuring Methods

Contributor:

Erik Trostmann

July 11 - 12, 2007, Penang (Malaysia)

Improving Business Performance through Sustainability-CSR-Concepts and Applications (Workshop)

Presentation:

- Executive Information Seminar: Improvement of Business Performance and Competitiveness by Applying Corporate Social Responsibility (CSR) Concepts and Solutions

Contributor:

Ralf Opierzynski

September 13 - 14, 2007, Magdeburg

Power Plant Professional Forum

Host:

Fraunhofer IFF, TÜV Rheinland

Presentations:

- Utilizing the Potentials of Experience with Condition-based Maintenance Strategies
- Recovering Energy from Biomass in Distributed Plants
- A Biomass Power Plant as an Example of Using Virtual Technologies for Product Development and Operation

Contributors:

Dr. Gerhard Müller

Dr. Martin Endig

Frank Ryll

Dr. Sascha Thomas

September 13 - 23, 2007, Frankfurt a.M.

IAA International Motor Show

(Trade Fair)

Host: OICA, VDA e.V.

Exhibits:

- FAM Ship Loading System and Flaking Mill as Examples of Virtual Interactive Training Scenarios

Contributors:

Armin Wagner

Steffen Masik

Wilhelm Termath

Johannes Tümler

Rolf Walter

Alexander Kroys

September 19, 2007, Magdeburg

Opening of the VIDET Innovation Cluster and the Polymer Technology Innovation Cluster

Host:

Fraunhofer IFF, Fraunhofer IWM, Saxony-Anhalt Ministry of Economics and Labor

Direction:

Prof. Michael Schenk

Contributors:

Dr. Gerhard Müller

Dr. Ulrich Schmucker

Torsten Böhme

Virtual reality shortens and facilitates the development of new products. The Virtual Development, Engineering and Training Innovation Cluster intends to increase the accessibility of such technologies to the machinery and plant manufacturing industry in Saxony-Anhalt.

The Fraunhofer Institute for Factory Operation and Automation IFF, Otto von Guericke University Magdeburg, the Max Planck Institute for Dynamics of Complex Systems and the regional large machinery and plant manufacturing industry, e.g. the machine tool manufacturer SCHIESS, will be collaborating in the cluster. The Fraunhofer IFF will coordinate the project. "One task is to develop methods and tools that enable the integrated use of virtual engineering and virtual reality throughout the product life cycle," explains Fraunhofer IFF Director Michael Schenk. In addition, the use of virtual reality for employees training and qualification is intended to be increased.



Saxony-Anhalt will be home to two Fraunhofer Innovation Clusters. Prof. Wehrspohn, Director of the Fraunhofer IWM in Halle, Prof. Buller, Fraunhofer-Gesellschaft Senior Vice President Research Planning, Minister of Economics and Labor Haseloff and Prof. Schenk, Director of the Fraunhofer IFF in Magdeburg, (l. to r.) announced this at a press conference.

Photo: Viktoria Kühne



Major carmakers send their cars to race in the German Stock Car Championship (DTM). Researchers from the Fraunhofer IFF developed an intelligent rear spoiler for their industry partner TR Engineering. Sensitive sensors make it possible to actively influence aerodynamics so that the optimal ratio of downforce and drag can already be determined during test drives.
Photo: Anna-Kristina Wassilew

September 24 - 29, 2007, Leiria (Portugal)

VR@P 2007: 3rd International Conference on Advanced Research in Virtual and Rapid Prototyping (Conference)

Host:
Institute Polytechnic of Leiria
Presentation:

- Using Intelligent Prototypes to Improve the Aerodynamic Design of Race Car Aerofoil Profiles

Contributor:
Dr. Uwe Klaeger

September 28, 2007, Magdeburg
IFF Colloquium

Host:
Fraunhofer IFF
Presentations:

- Interaction of Sound in Virtual Reality: Applications to the Digital Factory and other Uses
- Detection and Evaluation of Defects in Mono and Polycrystalline Silicon and Their Influences on Wafer Stability
- One-Stop Services for Worldwide Industrial Production
- Using Image Processing and Adaptive Dynamic Map Matching to Enhance the Precision of Localization System

Direction:
Prof. Michael Schenk

Contributors:
Carlo Belardinelli
Jens Ruhnnow
Jian Xu
Jörg von Garrel
Martin Kirch
Matthias Kennel
Tamas Juhasz
Tobias Lietz

October 16 - 18, 2007, Munich

MAINTAIN International Trade Fair for Industrial Maintenance

Host:

Exhibits: Messe München GmbH

- Mobile RFID Systeme from the Fraunhofer IFF's LogMotionLab
- Software to Support Plant Management Systems and Suitably Archive Documentation for Customers

Contributors:

Cathrin Plate

Uwe Amreihn

Dr. Martin Endig

Frank Ryll

October 17 - 19, 2007, Berlin

24th German Logistics Congress

Host:

German Logistics Association (BVL)

Exhibits:

- IFF Smart Box
- RFID Glove
- Off-road Navigation
- Solutions for Low-risk Logistics
- World Class Launch: Study for MBtech Consulting GmbH

Direction:

Prof. Michael Schenk

Contributors:

Helmut Röben

Daniel Reh

Tobias Reggelin

Katja Barfus

Holger Seidel

October 18, 2007, Brussels (Belgium)

Collaborating into the Future:

Empowering SME to Innovate

Host:

smE-MPOWER Konsortium

Contributors:

Andreas Wolf

Katrin Reschwamm

The Fraunhofer IFF presented itself at the BVL's German Logistics Association Congress in Berlin on October 17 through 19, 2007. German Chancellor Angela Merkel opened the event. In his role as a BVL Board Member, Director Michael Schenk presented the international 2007 German Logistics Research Award .

Experts from academia, research and business meet every year at the German logistics industry's most important event. The Fraunhofer IFF presented its services in the field of low-risk logistics, off-road navigation and secure chains of goods.



The Research Award ceremony at the 24th BVL Congress.
Photo: BVL

Coordinated by the Fraunhofer IFF, the smE-MPOWER initiative has made it its job to provide small and medium-sized enterprises in Europe support to effectively take advantage of the opportunities for research and developing funding to which they are entitled. The intention is to overcome existing obstacles to strengthen enterprises by holding workshops intended to clarify internal potentials and creating European-wide networks.

The conference in Brussels provided all the participating and interested parties an opportunity to exchange experiences and discuss new strategies of innovation management to enhance future collaboration.

For years, virtual technologies have been an integral part of product and process development, e.g. in the aviation, power engineering, machinery manufacturing and automotive industries. They replace physical objects and thus allow training highly complicated actions or experimenting free of risk in a computer generated interactive 3-D environment. These technologies have also entered medicine and are increasingly establishing themselves.

At the 4th Guest Lecture Series on virtual reality, top speakers from business and research reported on the use of VR and AR technologies in their organizations. The experts speaking on this topic provided insight into the applications of the technologies, e.g. in state-of-the-art product development or employee qualification.



Augmented reality for warehouse expediting.
Photo: Viktoria Kühne

October 23, 2007, Magdeburg

Vocational Education for Sustainable Development

Host:

Otto von Guericke University Magdeburg,
Fraunhofer IFF

Presentation:

- Didactic Principles for Organizing Learning Environments to Foster Skills to Sustainably Organize Manufacturing Processes

Exhibit:

- Virtual Reality Scenarios for Basic and Advance Vocational Training

Contributor:

Wilhelm Termath

October 25 - December 5, 2007, Magdeburg

Guest Lecture Series: Virtual Reality:

Human and Machine in Interactive Dialog

Host:

Fraunhofer IFF

Direction:

Prof. Michael Schenk, Fraunhofer IFF
Magdeburg

Prof. Ullrich Gabbert, Otto von Guericke
University Magdeburg

Prof. Roland Kasper, Otto von Guericke
University Magdeburg

Prof. Karl-Heinrich Grote, Otto von
Guericke University Magdeburg

Prof. Bernhard Preim, Otto von Guericke
University Magdeburg

Prof. Klaus Jenewein, Otto von Guericke
University Magdeburg

Patronage:

Dr. Reiner Haseloff, Saxony-Anhalt
Minister of Economics and Labor

Contributor:

Michaela Schumann

October 25 - 26, 2007, Erlangen

10 Years of Fraunhofer Vision

Anniversary Event

Host:

Fraunhofer "Vision" Alliance

Presentation:

- In-process Optical 3-D Measurement:
Methods and Examples of Practical
Application

Contributors:

Dirk Berndt

November 6, 2007, Havana (Kuba)

Logmark (Conference)

Presentation:

- Research for Real World Use

Contributors:

Prof. Burghard Scheel

November 6 - 8, 2007, Stuttgart

VISION 2007: 20th International Trade
Fair for Machine Vision and Identification
Technologies

Host: Messe Stuttgart GmbH

Exhibit:

- Optical 3-D Metrology

Contributors:

Dirk Berndt

Ralf Warnemünde

Steffen Sauer

November 7, - 8, 2007, Berlin

TA Cook Conference

RFID in Maintenance

Presentations:

- Paperless and Efficient Support for
Company Processes with RFID
- Reliability in the Spare Part Supply
Chain in the Aviation Industry RFID

Contributors:

Prof. Michael Schenk

Helmut Röben

Together with the VDI Maintenance Expert Committee, the Forum Vision Maintenance FVI and other partners, the Fraunhofer Institute for Factory Operation and Automation IFF is a member of the Maintenance Team RFID (MTR). They jointly hosted the 3rd Annual FVI Forum on "RFID in Maintenance".

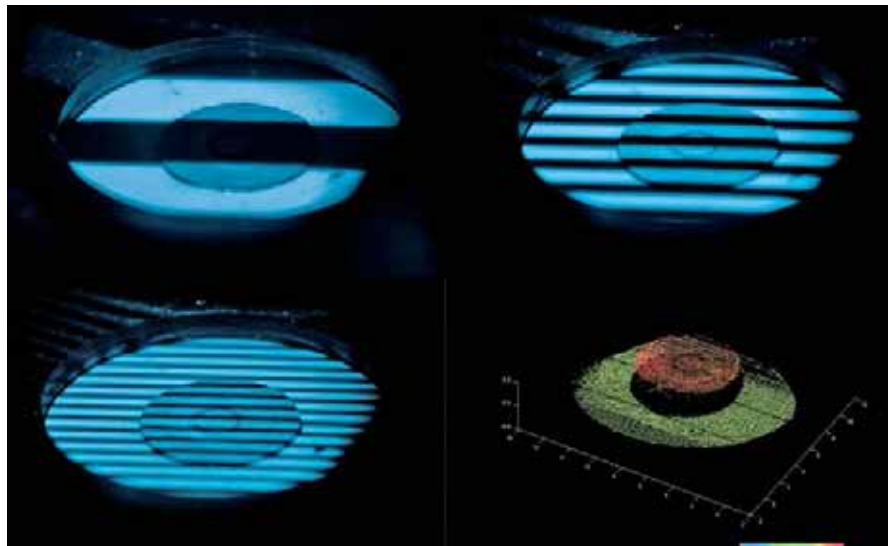

A model application of optical 3-D metrology from the Fraunhofer IFF: Specialists from the Fraunhofer IFF developed a special measuring system for the aircraft manufacturer Airbus, which inspects whether rivets on an airplane hull have been set right. A fringed pattern is projected on the head of a rivet and recorded by a camera. A point cloud can be calculated from this information.

BASF AG invited the participants of the 8th Industry Working Group, including some 60 industrial enterprises from the chemical and power plant manufacturing industry, to Ludwigshafen. The event focused on the issue of "Project Management in Plant Engineering". Manager and CEOs from different companies spoke on the challenges and advantages of project controlling and the trends in project management.



One of the Society for the Promotion of Renewable Energies' speakers was Martin Pokojski from Vattenfall AG.
Photo: Viktoria Kühne



Attendees from all over Germany traveled to Magdeburg in response to an invitation from the working group on "Biogases - Fuel Cells". The event concentrated on the "Potentials of Operating Fuel Cells with Gasification Gas". Photo: Viktoria Kühne

November 8, 2007, Ludwigshafen

8th Industry Working Group:
Cooperation in Plant Engineering

Host:

Fraunhofer IFF, FASA

Exhibit:

– Engineering Workstation

Contributors:

Dr. Eberhard Blümel

Andrea Urbansky

Melanie Thurow

Ronny Franke

November 22 - 23, 2007, Stuttgart

Optical 3-D Metrology for Quality Assurance in Production

Host:

Fraunhofer "Vision" Alliance

Presentations:

– Three-dimensional Offline and Online Inspection of Workpiece Geometry

Contributor:

Dirk Berndt

December 6, 2007, Erlangen

Inspection and Characterization of Surfaces with Image Processing

Host:

Fraunhofer "Vision" Alliance

Presentation:

– Integrated Optical Measurement and Surface Inspection of 3-D Objects

Contributors:

Dirk Berndt

December 10, 2007, Magdeburg

17th Meeting of the Society for the Promotion of Renewable Energies (FEE)

Host: FEE

Presentation:

– Presentation of the Fraunhofer IFF's Process and Plant Engineering Business Unit

– Biomass Gasification to Produce Fuel Gas for Fuel Cells

Collaboration:

Dr. Matthias Gohla

Dr. Sascha Thomas

Dr. Eyk Schotte

Appendix:
Names, Data, Publications



Photo: Viktoria Kühne



Saxony-Anhalt Center for Renewable Energies

ZERE

Objectives

The Saxony-Anhalt Center for Renewable Energies ZERE was founded on April 5, 2006 at the prompting of the Saxony-Anhalt Ministry of Economics and Labor. As a comprehensive initiative for professional exchange and the bundling and coordination of activities of commercial enterprises and research organizations working in different technical disciplines, the association is a response to the state of Saxony-Anhalt's ambitious aims to consolidate and extend its leadership in the field of renewable energies. This not only entails actively collaborating and implementing Germany's commitment to generate 12.5 percent of its power from renewable energy sources by 2010 and 20 percent by 2020 but also, above all, to secure Saxony-Anhalt as a center of this dynamically growing market segment from the perspective of business strategy. Saxony-Anhalt was already able to point to a 20.4 percent share of the net power generation from this source in 2005 and, thus, is a national trendsetter to a certain extent.

Its 69 percent utilization of wind energy played a significant part. At 25 percent and with steadily expanding distributed use in biomass cogeneration plants, the use of thermal technologies and fermentation to recover energy from biomass is headed in a good direction. The percentage share of solar power in power generation has tripled in just a few years. The strong development and centering of the solar industry in the state of Saxony-Anhalt is expected to significantly increase this share in the coming years. The capacities installed for the production of fuel and biogas from renewable raw materials using first generation technologies is another feature that positively

sets Saxony-Anhalt apart from other German states. 61 percent of the bioethanol and 16 percent of the biodiesel produced in all of Germany is produced in Saxony-Anhalt. Over 100 biogas production plants are in operation in the state.

In the future, it will also be essential to increasingly take advantage of the positive position already attained in this sector of energy industry applications and fuel production to develop second generation technologies and implement them in practice. Continuing and expanding the range of uses for renewable energy technologies according to the requirements of advanced state-of-the-art is indispensable for future orientation in national and international competition. The potentials for this are on hand in our state, which has a traditionally good base in mechanical and plant engineering and favorable prerequisites for regional agro-forest resources and industrial growth cores.

With these boundary conditions for development in plant engineering and operation, emphases for the organization of the association's substantive work tailored for the future have been identified in the following domains:

- Further increasing efficiency and solving problems of storage for wind power,
- Applying new active principles and thin-film modules in photovoltaics,
- Producing fuel from biomass on the basis of second generation processes,
- Combusting and gasifying biomass (agro-forest biomass and biogenic wastes) efficiently in bio-cogeneration plants,
- Substituting biogas for natural gas,
- Introducing new energy conversion systems (fuel cells to industrially produce hydrogen),
- Utilizing CCS technologies including CO₂ storage,



Zere general meeting in November 2007. Photo: Zere e.V.

- Coupling renewable energy systems for base load requirements,
- Distributing electricity innovatively and stably (intelligent networks) and
- Utilizing geothermal for shallow and deep hole drilling (electrical power, heat).

The field of innovative development and practical application will increasingly move toward the fore of market development and necessitate close ties between business and research. ZERE intends to effectively contribute to this. The association's goals are to support and disseminate innovative technologies to apply renewable energies. Specifically, this involves:

- Contracting research,
- Supporting applied research,
- Furthering cooperation between scientific research organizations and industry partners,
- Holding professional and informational events and
- Actively performing public relations work related to the activities in the field of renewable energies.

Work

The broad range of scientific and engineering disciplines relevant to the field of renewable energies makes one fundamental task a bundling function as a contact point for the exchange of experience and knowledge transfer in the relatively broad market segment of renewable energy technology including corresponding technical fields of resource conservation and logistics. On the one hand, cross-industry and interdisciplinary problems with the utilization of wind, solar, biomass, hydrogen and geothermal

are growing increasingly important, not least from the perspective of interconnecting systems for intermittent power output to obtain continuous base loads and power storage and distribution both in distributed plants and in different connected primary energy systems.

Among other things, expert coordination and management work is situated here. On the other hand, a crucial objective is to concretely contribute to current R&D and implementation actions in complex joint projects. The member structure is accordingly oriented toward close interaction by focusing on the practical implementation of joint research and technical projects. The membership of companies and organizations (plant manufacturers, developers and operators) is geared toward efficiency conducive to the goals. They contribute their own capacities and already existing business and research expertise.

Given the aforementioned premises, the members currently active in ZERE cover every current field of work. They are able to flexibly adapt to new requirements arising from this new branch of industry's dynamic development. The pertinence of concrete tasks and professional collaboration on suitable projects is a priority.

Concentrating on the technological contents of innovative renewable energy use, the membership is concerned with non-profit and professionally neutral association work and thus uninterested in striving for government positions or political lobbying.

The current board:

President

Prof. Zbigniew A. Styczynski
Otto von Guericke University Magdeburg

Vice President

Dr. Hans-Jürgen Rasehorn
Cimbria SKET GmbH

Treasurer

Dr. Gerhard Müller
Fraunhofer IFF

reflects the organizations and companies significantly involved in the initiative to found and the establishment of this association. They also professionally coordinate the present work concentrated on.

ZERE is a member of the Central European Power Research Institute (CEPRI) and through this involvement also internationally active beyond the state's borders.

Contact

Dr. Günter Heideck, Geschäftsführer
ZERE Zentrum für Regenerative Energien
Sachsen-Anhalt e.V.
c/o Otto-von-Guericke-Universität
Magdeburg
Institut für Elektrische Energiesysteme
(IESY)
Universitätsplatz 2, 39106 Magdeburg
Germany
Tel. +49 391/6 71-16 48
Fax +49 391/6 71-24 08
Guenter.Heideck@zere-ev.de

Committee Work in 2007 (Selection)

ALFA Growth Core
Susan Gronwald - Growth Core Advisory Board

AMA Fachverband für Sensorik e.V.
Dr. Ulrich Schmucker – Member

Asian Society for Environmental Protection (ASEP)
Ralf Opierzynski – Member

Association for the Promotion of Materials Cycle Management
Doz. Lutz Hoyer – Member of the Board
Frank Mewes – Member

Association for the Promotion of Mechanical and Plant Engineering in Saxony and Saxony-Anhalt FASA
Prof. Michael Schenk – Chairman of the Board
Andrea Urbansky – Managing Director

Association for the Promotion of Power and Environmental Engineering (VEU)
Dr. Lutz Hoyer – Member

Association of German Engineers (VDI) Saxony-Anhalt VDI State Chapter
Prof. Michael Schenk – Chairman
Magdeburg VDI District Association
Dr. Klaus Richter – Ombudsman for the Development, Engineering and Sales Working Group
Dr. Mirko Peglow – Ombudsman for the Students and Young Engineers' Working Group

Association of German Engineers (VDI) VDI Environmental Engineering Coordination Office (VDI-KUT), Industrial Environmental Management Performance Indicators Working Group
Ralf Opierzynski – Member

Association of German Engineers (VDI) VDI Society for Industrial Engineering (ADB)

Dr. Gerhard Müller – Member of the Board and Head of the Plant Management Competence Field
VDI Factory Planning Guidelines Working Group
Thomas Dengler – Committee Member and Contributor to the Working Group

Association of German Engineers (VDI) VDI Society of Metrology and Automation (GMA)
Technical Committee 3.32: Optical 3-D Metrology
Dirk Berndt – Private Member

Association of German Foundry Experts (VDG)
Prof. Michael Schenk – Member of the Research Advisory Board
Sonja Hintze – Member

ATV-DVWK Research Group ES-8.12 Repair of Sewer Lines and Systems with Robotic Systems
Dr. Norbert Elkmann – Member

BITCOM e.V.
Prof. Michael Schenk – Fraunhofer-Gesellschaft Representative
Dr. Ina Ehrhardt – Fraunhofer-Gesellschaft Representative

CEN TC 319 Maintenance
Cathrin Plate – Member

Center for Neuroscientific Innovation and Technology ZENIT GmbH
Prof. Michael Schenk – Member of the Scientific Advisory Board

Central German Waste Management Industry Competence Network
Dr. Eyck Schotte – Member of the Renewable Energies Working Group
Dr. Lutz Hoyer – Member of the Substitute Fuels Working Group

CLAWAR Association Dr. Ulrich Schmucker – Member	Fraunhofer-Gesellschaft Fraunhofer Group for Production Prof. Michael Schenk – Member	IGZ Innovations- und Gründerzentrum Magdeburg GmbH Prof. Michael Schenk – Member of the Advisory Board
Comprehensive Center for Transportation Braunschweig (GZVB) Eyk Flechtner – Member	Fraunhofer Group for Energy EST Dr. Lutz Hoyer – Coordinator of Fraunhofer IFF Activities	International Green Productivity Association (IGPA) Ralf Opierzynski – Member
EU Commission's 6th Framework Programme Dr. Eberhard Blümel – Expert	Fraunhofer Group for Nanotechnologies Dr. Ulrich Schmucker – Member	Jenoptik AG, Scientific Advisory Board Prof. Michael Schenk – Member
European Intermodal Research Advisory Council EIRAC Dr. Eberhard Blümel – Member	Fraunhofer Traffic and Transportation Alliance FVV Dirk Berndt – Fraunhofer IFF Spokesman Daniel Reh – Member	Karl Heinz Beckurts Foundation Prof. Michael Schenk – Member
European Technology Platform – Industrial Safety ETPIS Dr. Eberhard Blümel – Member	Fraunhofer Vision Alliance Dirk Berndt – Fraunhofer IFF Spokesman	Licon Logistics e.V. Dr. Klaus Richter – Member of the Board
Federal Association for Industrial Engineering, Business Organization and Corporate Development REFA, Saxony-Anhalt State Chapter Holger Seidel – Member of the Extended Board	German Business Rationalization and Innovation Center RKW in Saxony-Anhalt Dr. Gerhard Müller – Member of the Board	LPQIVES – Leonardo Power Quality Initiative Vocational Education System Certification Board Przemyslaw Komarnicki – Member
Forum Vision Maintenance Cathrin Plate – Member, Fraunhofer IFF Representative in the Consortium	German Construction Technology Platform, Cultural Heritage Working Group Dr. Rüdiger Mecke, Andreas Hoepfner – Contributors	Magdeburg CCI Transportation Committee Holger Seidel – Member
Fraunhofer Energy Alliance Dr. Lutz Hoyer – Coordination of IFF Activities (on behalf of Institute Management)	German Logistics Association (BVL) Prof. Michael Schenk – Member of the Executive Board and the Steering Committee Saxony-Anhalt Regional Chapter Holger Seidel – Regional Spokesman	MAHREG Saxony-Anhalt Automotive Competence Network Dr. Gerhard Müller – Fraunhofer IFF Representative
Fraunhofer Energy Alliance (EST) Dr. Matthias Gohla – Coordinator of Fraunhofer IFF Activities (on behalf of Institute Management)	German-Russian Forum Prof. Michael Schenk – Member	MLFU Coordination Office for Renewable Raw Materials KoNaRo (LSA) Dr. Lutz Hoyer – Member of the Biogenic Fuels Working Group
Fraunhofer-Gesellschaft FhG Scientific-Technical Board WTR Prof. Michael Schenk – Member of the Main Commission Dr. Gerhard Müller – Fraunhofer IFF Representative Dr. Uwe Klaeger – Deputy Fraunhofer IFF Representative	German Society for Nondestructive Testing DGZfP Magdeburg Working Group Dirk Berndt – Private Member	North Rhine-Westphalian User Association for Integrate Satellite Navigation Solutions Navisat Prof. Michael Schenk – Member
		Open GIS Consortium (OGC) Frank Mewes
		Pipeline and Plant Engineering Network Andrea Urbansky – Member of the Coordinating Board

Practical Forum for Competence Management

Mark Staiger – Coordinator

REFA/VDG Foundry Expert Committee

Federal Association for Industrial Engineering, Business Organization and Corporate Development

Sonja Hintze – Member

Saxony-Anhalt Center for Renewable Energies (ZERE)

Dr. Gerhard Müller – Member of the Board

Dr. Matthias Gohla – Fraunhofer IFF Contact

Saxony-Anhalt Satellite Navigation SANASA

Dr. Klaus Richter – Chairman of the Board

Simulation Working Group

Distributed Modeling and Simulation Expert Group

Marco Schumann – Member

Simulation Working Group

Dr. Juri Tolujew – Member

Society for Computer Science GI

Ralf Opierzynski – Member of the Industrial Environmental Information Systems Research Group

Society for Knowledge Management

Mark Staiger – Mitglied

Society for Modeling and Simulation International

Dr. Steffen Strassburger – Member

Society for Operations Research

Holger Seidel – Member

Society for Project Management

Magdeburg Regional Chapter

Katrin Reschwamm – Head of Regional Chapter

Society for the Promotion of Renewable Energies FEE

Biogenic Gases - Fuel Cells Working Group

Dr. Matthias Gohla – Member

Biomass Gasification Working Group

Dr. Helmar Tepper – Member

The International Emergency Management Society

Dr. Martin Endig – Member

TKB – Technologiekontor Bremerhaven

F&E Gesellschaft für die Nutzung regenerativer Energien m.b.H.

Prof. Michael Schenk – Advisory Board Member

Transfer Center for Automation in Mechanical Engineering (TAM)

Dr. Ulrich Schmucker – Member of the Board

VDI-ADB Holistic Production Systems Expert Committee

Setup, Structure and Goals of Holistic Production Systems Working Group

Rolf Walter – Committee Member

VDI-ADB – Maintenance Expert

Committee

Guidelines Formulation Working Group

Cathrin Plate – Committee Member and Contributor to the Working Group

Wind Energy Agency Bremerhaven/ Bremen (WAB)

Dr. Klaus Richter – Technical Contributor

Frank Ryll – Member

International Research and Cooperation Partners in 2007 (Selection)

Aeronautical Institute Kharkov, Kharkov, Ukraine	CENTRIM University of Brighton, Brighton, Great Britain
AIDIMA, Valencia, Spain	Centro Ricerche FIAT (CRF), Orbassano (Torino), Italy
ALMA, Lyon, France	Centrul De Afaceri Transilvania (CAT), Cluj-Napoca, Romania
ARIES, Bucharest, Romania	CEPE – Centre for Energy Policy and Economics, Swiss Federal Institute of Technology Zurich, Zurich, Switzerland
Asia Pacific Roundtable for Cleaner Production (APRCP), Manila, Philippines	Chalmers University of Technology, Göteborg, Sweden
Asian Society for Environmental Protection (ASEP), Bangkok, Thailand	Chengdu Lead Science & Technology Co. Ltd. (SCLEAD), Chengdu, China
Atos Origin, Madrid, Spain	College of Nyíregyháza, Nyíregyháza, Hungary
Beacontech Ltd., Tel Aviv, Israel	CTO – Ship Design and Research Centre, Gdansk, Poland
Beijing Hope Software Co., Beijing, China	Czech Technical University Prague, Prague, Czech Republic
Biomag, Ing. Cerny, Uníčov, Czech Republic	DaimlerChrysler Forschungszentrum, Ulm
Brno University of Technology, Brno, Czech Republic	DaimlerChrysler, Gaggenau
Budapest University of Technology and Economics, Budapest, Hungary	Deere & Co. World Headquarter, Moline, Illinois, USA
Bureau of Target Industries Development/ Department of Industrial Promotion (Ministry of Industry), Bangkok, Thailand	Delft University of Technology, Delft, Netherlands
Cámara Oficial de Comercio, Industria y Navegación de Valencia, Valencia, Spain	Digipro Computer Consultants Ltd, Pafos, Cyprus
Centrale Recherche SA, Paris, France	e.sigma Systems GmbH, Munich
Centre for Renewable Energy CRES, Pikermi Attiki, Greece	EADS Deutschland GmbH, Ulm
Centre for Research and Technology Hellas CERTH, Ptolemais, Greece	Ecole Centrale Paris, Paris, France
Centre for Research and Technology Hellas, Thermi, Thessaloniki, Greece	Ecole Polytechnique Universitaire de Marseille, Marseille, France

Enigma Information Retrieval, Inc, Burlington, Massachusetts, USA	Industrial Technology Research Institute, Taipei, Taiwan	Klaipeda State Seaport Authority, Klaipeda, Lithuania
Escola Superior Agraria de Beja, Beja, Portugal	Institut für Diagnostik und Konservierung an Denkmälern in Sachsen und Sachsen- Anhalt e.V., Halle	Kohlbach KCO GmbH, Wolfsberg, Austria
EURESEARCH, Bern, Switzerland	Institut National de Recherche en Informatique et en Automatique (INRIA), Sophia Antipolis, France	Laboratory of Design, Production and Management, Universiteit van Twente, Twente, Netherlands
European Process Safety Centre, Warwickshire, Great Britain	Instituto de Engenharia de Sistemas e Computadores do Porto (INESC), Porto, Portugal	State Forestry Enterprise of the Slovak Republic, Banská Bystrica, Slovak Republic
Federation of Thai Industries (FTI), Bangkok, Thailand	Instituto de Tecnología Cerámica-AICE (ITC), Castellón, Spain	State Forestry Enterprise of the Czech Republic, Hradec Králové, Czech Republic
Forest and Landscape Denmark, University of Copenhagen, Hoersholm, Denmark	Instituto de Engenharia de Sistemas e Computadores do Porto (INESC), Porto, Portugal	Latvian Intelligent Systems, Riga, Latvia
Forest Research, Northern Research Station, Roslin, Midlothian, Schottland, Great Britain	Instytut Spawalnictwa, Polish Welding Centre of Excellence, Cracow, Poland	Lesy České republiky, státní podnik, Hradec Králové, Czech Republic
Forestry and Game Management Research Institute, Jiloviste-Strnady, Czech Republic	InterBalt Maritime Agency, Tallin, Estonia	Liophant Simulation Club, University of Genoa, Genoa, Italy
Georgia Institute of Technology, Atlanta, Georgia, USA	Intro Solutions Ltd., Ankara, Turkey	Lithuanian Innovation Centre (LIC), Vilnius, Lithuania
Hanoi University of Technology, Hanoi, Vietnam	Iowa State University, Ames, Iowa, USA	Liverpool John Moores University Higher Education Corporation, Liverpool, Great Britain
Hellenic Institute of Transport, Thessaloniki, Greece	Italian Ship Research Center (CETENA SpA), Genoa, Italy	Logitrans Consult Ltd., Tallin, Estonia
Higher Council for Science and Technology, Amman, Jordan	ITI Aristotle University Thessaloniki, Thessaloniki, Greece	Lund University, Lund, Sweden
IDC Information Technologies, Riga, Latvia	Jenoptik AG/Jenoptik Laser Display Technology LDT GmbH, Jena	Maritime & Supply Chain Solutions (Europe) Ltd., Ballycarry, Great Britain
Indian Institute of Science, Bangalore, India	Joint Research Company, Ispra, Italy	Massachusetts Institute of Technology, Cambridge, Massachusetts, USA
Indo German Chamber of Commerce, Bangalore, India	Sonex Computers Joint Stock Company (SONEX Group), Klaipeda, Lithuania	Melon Technologies, Sofia, Bulgaria
Indonesian Society of Environmental Professionals (ISEP), Jakarta, Indonesia	Jordan University for Science and Technology, Amman, Jordan	Metla, The Finnish Forest Research Institute, Parkano, Finland
	Karl-Franzens-University, Graz, Austria	Moscow State Automobile and Road Technical University MADI, Moscow, Russia
	King Mongkut's University of Technology Thonburi (KMUTT), Bangkok, Thailand	

Multimedia University Malaysia, Cyber Jaya, Malaysia	Opto-Electronic Engineering Institute, Southwest Jiaotong University, Chengdu, China	The Open University, Milton Keynes, Great Britain
National Science and Technology Development Agency (NSTDA), Pathumthani, Thailand	SP Swedish National Testing and Research Institute, Boras, Sweden	Thessaloniki Port Authority, Thessaloniki, Greece
Nemetschek, Sofia, Bulgaria	Russian Institute of Aviation Systems (GosNIIAS), Moscow, Russia	TP Technoplus Industrial and Trading Ltd, Budapest, Hungary
Netherlands Organization for Applied Scientific Research, Delft, Netherlands	Stanford University, Stanford, California, USA	Trans-European Consultants for Transport, Development and IT (TREDIT), Thessaloniki, Greece
Niki Information Technologies, Katsika, Greece	Steinbeis-Transferzentrum Qualitäts-sicherung & Bildverarbeitung, Ilmenau,	TRIMOS-SYLVA S.A. (PTY) Ltd., Waterkloof, South Africa
Office of Small and Medium Enterprises Promotion (OSMEP), Bangkok, Thailand	Technical University of Crete, Crete, Greece	Trinity College Dublin, Dublin, Ireland
Philippine Pollution Prevention Roundtable (P3R), Manila, Philippinen	Technical University of Lisbon, Lisbon, Portugal	Tsinghua University, Peking, China
PIAP Industrial Research Institute for Automation and Measurement, Warsaw, Poland	Technical University of Sofia, Sofia, Bulgaria	T-Systems, Frankfurt am Main
Plato, Dundalk, Ireland	Department of Quality Assurance, School of Mechanical Engineering, Technical University Ilmenau, Ilmenau	TÜV Rheinland Industrie Services GmbH, Cologne
Politecnico di Milano, Milan, Italy	School of Forestry Zvolen, Technical University, Zvolen, Slovak Republic	Universidad Politicnica de Valencia, Valencia, Spain
Pymera, Valencia, Spain	TESEO Sprl, Brussels, Belgium	Universidad Rovira e Virgil, Tarragona, Valencia, Spain
Regionalne Poradenske A Infomacne Centrum Presov (RPIC), Presov, Slovak Republic	Testaluna S.r.l., Milan, Italy	Universita Cattolica del Sacro Cuore di Milano, Milan, Italy
Riga Technical University, Riga, Latvia	Thai-German Institute (TGI), Chonburi, Thailand	Universita degli Studi di Genova, Genoa, Italy
Semantic Systems, Derio, Spain	Thales Aerospace Division, Toulouse, France	Universita di Napoli, Naples, Italy
SenterNovem, Den Haag, Netherlands	Thales Defence Deutschland GmbH, Koblenz	Universität Modena, Modena, Italy
SFERA Societa per la Formazione e le Risorse Aziendali per Azioni, Italy	Thales Netherlands B.V, Hengelo, Netherlands	Universität Zurich, Zurich, Switzerland
Sheffield Hallam University, Sheffield, Great Britain	Thales Research and Technology, Berkshire, Great Britain	Université de Haute Alsace, Mülhausen, France
Skogforsk, The Forestry Research Institute of Sweden, Uppsala, Sweden		Université de Valenciennes, Valenciennes, France

Universite Libre de Bruxelles, Brussels, Belgium	University of Ulster, Ulster, Northern Ireland
University College of Borås, Borås, Sweden	University of Zilina, Zilina, Slovak Republic
University of Applied Science Karlsruhe, Institute of Applied Research (IAF), Karlsruhe	VDH USA Inc, Millerville, Maryland, USA
University of Athens, Athens, Greece	Vietnam Productivity Centre (VPC), Hanoi, Vietnam
University of Birmingham, Birmingham, Great Britain	Virginia Modeling, Analysis and Simulation Center (VMASC), Norfolk, Virginia, USA
University of Glasgow, Glasgow, Scotland	Vocational Education Development Center (VEDC), Malang, Indonesia
University of Halmstadt, Halmstadt, Sweden	VR Centre, University of Teesside, Middlesbrough, Great Britain
University of Helsinki, Helsinki, Finland	VTT Technical Research Centre of Finland, Espoo, Finland
University of Malaga, Malaga, Spain	Warsaw University of Technology, Warsaw, Poland
University of Michigan, Virtual Reality Laboratory, Ann Arbor, Michigan, USA	
University of Nottingham, Nottingham, Great Britain	
University of Oulu, Neural Network Group, Oulu, Finland	
University of Porto, Decision and Control Engineering Group (DCEG) from FEUP, Porto, Portugal	
Sapienza University of Rome, Rome, Italy	
University of Southern Queensland, Toowoomba, Australien	
University of Tampere, Tampere, Finland	
University of Trondheim, Trondheim, Norway	

Publications in 2007

Monographs and Editorships (Selection)

Schenk, M. (Ed.):
3rd and 4th IFF Colloquium – Forschung vernetzen – Innovationen beschleunigen.
Magdeburg : Fraunhofer IFF, 2007,
ISBN 978-3-8167-7557-7

Schenk, M. (Ed.):
10th Guest Lecture Series: Logistik als Arbeitsfeld der Zukunft – Potenziale, Umsetzungsstrategien und Visionen.
Magdeburg : Fraunhofer IFF, 2007
ISBN 978-3-8167-7356-6

Schenk, M. (Ed.):
10th IFF Science Days: Logistik – Intelligenz in Produktion und Verkehr: Virtual Reality and Augmented Reality zum Planen, Testen und Betreiben technischer Systeme.
Magdeburg : Fraunhofer IFF, 2007,
ISBN 978-3-8167-7383-2

Schenk, M. (Ed.):
10th IFF Science Days : Workshop – Robotertechnologien für den Einsatz in Alltagsumgebungen.
Magdeburg : Fraunhofer IFF, 2007, CD

Schenk, M. (Ed.):
Arbeitsbericht: 7. Industriearbeitskreis "Kooperation im Anlagenbau" – "Investitionsvorhaben und neue gesetzliche Anforderungen im Anlagenbau".
Magdeburg : Fraunhofer IFF, 2007
ISBN 978-3-8167-7447-1

Schenk, M. (Ed.):
Virtual Reality Guest Lecture Series 2007: Virtual Reality – Mensch und Maschine im interaktiven Dialog.
Magdeburg : Fraunhofer IFF, 2007
Vol. 4, ISBN 978-3-8167-7477-8

Schenk, M. (Ed.):
IFFOCUS: Logistics Connects; Logistics Intelligence in Manufacturing and Transportation.
Magdeburg : Fraunhofer IFF, 1.2007,
ISSN 1862-5320,
ISBN 978-3-8167-7381-8

Schenk, M. (Ed.):
IFFOCUS: Interactive Human-Machine: 15 Years of Fraunhofer in Saxony-Anhalt
Magdeburg : Fraunhofer IFF, 2007,
ISSN 1862-5320,
ISBN 978-3-8167-7537-9

Schenk, M. (Ed.):
Interlogistica Tagung "Logistische Prozesse in den Bereichen Luftfahrt, Automobil und Transportwesen: Qualität und Sicherheit".
Moscow: Fraunhofer IFF, 2007

Schenk, M. (Ed.):
Achievements and Results: 2006 Annual Report.
Magdeburg : Fraunhofer IFF, 2007

Preim, B. (Ed.) ; Teutsch, C.:
Model-based Analysis and Evaluation of Point Sets from Optical 3D Laser Scanners (Magdeburger Schriften zur Visualisierung).
Aachen : Shaker Verlag, 2007,
ISBN 978-3-8322-6775-9

Articles and Papers (Selection)

Bayrhammer, E. ; Kennel, M.:
Eine Schnittstelle zur echtzeitfähigen Kopplung heterogener Simulations-, Steuerungs- und Visualisierungsapplikationen.
In: Schenk, M. (Ed.):
3rd and 4th IFF Colloquium – Forschung vernetzen – Innovationen beschleunigen. (Magdeburg, September 28, 2007) – Proceedings, pp. 86-89,
ISBN 978-3-8167-7557-7

Belardinelli, C.:
Interaction of Sound in Virtual Reality: Applications to the Digital Factory and Other Uses.
In: Schenk, M. (Ed.):
3rd and 4th IFF Colloquium – Forschung vernetzen – Innovationen beschleunigen. (Magdeburg, September 28, 2007) – Proceedings, pp. 73-77,
ISBN 978-3-8167-7557-7

Blümel, E.:
Stand und Entwicklungstrends des Einsatzes von VR/AR – Techniken für Qualifizierung und Training im Arbeitsprozess.
In: Gesellschaft für Arbeitswissenschaft e.V. (Ed.):
Kompetenzentwicklung in realen und virtuellen Arbeitssystemen.
Dortmund : GfA-Press, Dortmund, 2007,
pp. 241-244, ISBN 978-3-936804-04-1

Dengler, T. ; Petri, R.:
Kontinuierliche Fabrikplanung im Generatorenbau.
In: Schenk, M. (Ed.):
IFFOCUS: Logistics Connects.
1.2007, pp. 36-38, ISSN 1862-5320

- Dürr, V. ; Krause, A. F. ; Neitzel, M. ; Lange, O. ; Reimann, B.:
Bionic Tactile Sensor for Near-range Search, Localisation and Material Classification.
In: Berns, K. ; Luksch, T. (Eds.):
20. Fachgespräch Kaiserslautern.
(Kaiserslautern, October 18 - 19, 2007) – Proceedings, pp. 240-246,
ISBN 978-3-540-74763-5
- Dzienis, C. ; Komarnicki, P. ; Styczynski, Z. A.:
Method for Optimal Localization of the Power Quality Monitoring Devices in Power Systems.
In: Powertech 2007.
(Lausanne, Switzerland, July 1 - 5, 2007) – Proceedings
- Ehrhardt, I.:
Foreword
In: One-Stop Services für die weltweite industrielle Produktion. Die Zeitschrift zum Verbundvorhaben OSS.
(2007) 2, pp. 3-4
- Ehrhardt, I. ; Kutzler, T. ; Wäsche, M.:
Telematiktechnologien und -dienste für die integrierte Logistik von BOS (Behörden und Organisationen mit Sicherheitsaufgaben).
In: Gesamtzentrum für Verkehr Braunschweig e.V. (Ed.):
POSITIONs Kongress 2007.
(Braunschweig, October 15 - 17, 2007) – Proceedings, pp. 98-109,
ISBN 978-3-937655-13-0
- Ehrhardt, I. ; von Garrel, J.:
Dienstleistungstypenschema für One-Stop Services.
In: One-Stop Services für die weltweite industrielle Produktion Die Zeitschrift zum Verbundvorhaben OSS.
(2007) 2, pp. 19-28
- Elkmann, N. ; Kutzner, S. ; Stuerze, T. ; Saenz, J. ; Reimann, B.:
Development of Fully Automatic Inspection Systems for Large Underground Concrete Pipes Partially Filled with Wastewater.
In: MM2007, 3rd International Conference on Maintenance and Facility Management.
(Rome, Italy, September 27 - 29, 2007) – Proceedings, pp. 111-116,
ISBN 9788895405025
- Elkmann, N. ; Lucke, M. ; Krüger, T. ; Kunst, D. ; Stürze, T.:
Kinematics, Sensors and Control of the Fully Automated Facade Cleaning Robot SiriusC for the Fraunhofer Headquarters Building, Munich.
In: 10th International Conference on Climbing and Walking Robots and the Supporting Technologies for Mobile Machines (Clawar).
(Singapore, Singapore, July 16 - 18, 2007) – Proceedings, pp. 169-176,
ISBN 139789812708151
- Endig, M. ; Gohla, M. ; Mewes, F.:
Qualifizierung und Kompetenzentwicklung als integraler Bestandteil moderner Produktservicestrategie am Beispiel verfahrenstechnischer Anlagen.
In: Gesellschaft für Arbeitswissenschaft (Ed.):
53. Frühjahrskongress der Gesellschaft für Arbeitswissenschaft e.V. – Kompetenzentwicklung in realen und virtuellen Arbeitssystemen
(Magdeburg, February 28 - March 2, 2007) – Proceedings
- Faber, T. ; Kissner, H. ; Kroys, A. ; Lange, A. ; Schulz, T. ; Termath, W.:
Virtuell interaktive Module zur innovativen Umsetzung der Maschinenrichtlinie.
In: wt Werkstatttechnik online.
(2007) 7/8, ISSN 1436-4980
- Fritzsche, M. ; Schulenburg, E. ; Elkmann, N. ; Girstl, A. ; Stiene, S. ; Teutsch, C.:
Safe Human-Robot Interaction in a Life Science Environment.
In: IEEE International Workshop on Safety Security and Rescue Robotics.
(Rome, Italy, September 27 - 29, 2007) – Proceedings
- Gabbert, U. ; Lefèvre, J. ; Nestorovic, T. ; Ringwelski, S.:
Analysis and design of smart structures to control vibration and noise.
In: ASME (Ed.):
ASME International Design Engineering Technical Conferences & Computers and Information in Engineering Conference, 21st Biennial Conference on Mechanical Vibration and Noise.
(Las Vegas, USA, September 4 - 7, 2007) – Proceedings,
pp. DETEC2007-34423,
ISBN 0-7918-3806-4
- Gabbert, U. ; Nestorovic, T. ; Wuchatsch, J.:
Methods and possibilities of a virtual design for actively controlled smart systems.
In: Computers & Structures.
(2007), pp. 240-250, ISSN 0045-7949
- von Garrel, J.:
Verbundvorhaben: One-Stop Services für die weltweite industrielle Produktion (OSS).
In: BMBF Program "Innovationen mit Dienstleistungen" – Themenheft zum Förderschwerpunkt "Exportfähigkeit und Internationalisierung von Dienstleistungen".
(2007), pp. 26-30

von Garrel, J. ; E. Kluge:
Leistungstiefengestaltung nationaler
Dienstleistungsnetzwerke auf inter-
nationalen Märkten.
In: www.dl2100.de.
20. June 2007

Hortig, J.:
Cleaning robots for vertical or vaulted
glass facades.
In: 3rd international Conference on
Maintenance and Facility Management.
(Rome, Italy, September 27 - 29, 2007) –
Proceedings, pp. 155-157
ISBN 9788895405025

Hortig, J.:
Ein Exkurs in die Servicerobotik.
In: MO – Metalloberfläche.
(2007), pp. 16 ff, ISSN 0026-0797

Juhasz, T.:
Automatic Model Conversion to Modelica
for Dymola-based Multi-Domain
Simulation.
In: Schenk, M. (Ed.):
3rd and 4th IFF Colloquium – Forschung
vernetzen – Innovationen beschleunigen.
(Magdeburg, September 28, 2007) –
Proceedings, pp. 65-68,
ISBN 978-3-8167-7557-7

Juhasz, T. ; Konyev, M. ; Rusin, V. ;
Schmucker, U.:
Contact Processing in the Simulation of
CLAWAR.
In: 10th CLAWAR International
Conference.
(Singapore, Singapore, July 16 - 18,
2007) – Proceedings, pp. 583-590,
ISBN 978-981-270-815-1

Juhasz, T. ; Urbancsek, T.:
Beyond the Limits of Kinematics in
Planning Keyframed Biped Locomotion.
In: 6th Eurosim Congress on Modelling
and Simulation.
(Ljubljana, Slovenia, September 9 - 13,
2007) – Proceedings, pp. 78,
ISBN 978-3-901608-32-2

Klaeger, U. ; Hoffmann, A.:
Using Intelligent Prototypes to Improve
the Aerodynamic Design of Race Car
Aerofoil Profiles.
In: Bartolo, P. J. (Ed.):
3rd International Conference on Virtual
and Rapid Manufacturing: Advanced
Research in Virtual and Rapid Proto-
typing.
(Leiria, Portugal, September 24 - 29,
2007) – Proceedings, pp. 807-810,
ISBN 978-0-415-41602-3

Komarnicki, P. ; Müller, G. ; Dzienis, C. ;
Styczynski, Z. A. ; Gollub, I. ;
Blumschein, J.:
PMU Placement method Based on
Decoupled Newton Power Flow and
Sensitivity Analysis.
In: 9th International Conference on
Electrical Power Quality and Utilization –
EPQU 2007.
(Barcelona, Spain, October 9 - 11, 2007)
– Proceedings,
ISBN 978-84-690-9441-9

Komarnicki, P. ; Müller, G. ; Dzienis, C. ;
Styczynski, Z. A. ; Phadke, A. ;
Blumschein, J.:
Optimized Testing Procedures for Phasor
Measurement Units.
In: 13th International Scientific
Conference: Present-Day Problems of
Power Engineering – APE '07.
(Jurata, Poland, June 13 - 14, 2007) –
Proceedings, pp. 145-152

Kumentz, S. ; Termath, W.:
Computersimulierte Produktionsszenarien
fördern nachhaltiges Handeln von mitt-
leren Führungskräften.
In: BWO Berufsbildung in Wissenschaft
und Praxis.
(2007) 5, pp. 22-23, ISSN 0341-4515

Kumetz, S. ; Termath, W. ; Zinn, J.:
Methoden selbstgesteuerten Lernens in
den neuen elektronischen Handwerks-
berufen.
In: berufsbildung Zeitschrift für Praxis
und Theorie in Betrieb und Schule.
(2007) 106, pp. 20-22, ISSN 0005 9536

Lange, A. ; Szymanski, H. ; Kissner, H. ;
Termath, W.:
Virtuell-interaktive Module zur inno-
vativen Umsetzung der EU Maschinen-
richtlinie: Partizipation der Akteure im
Lebenszyklus von Maschinen und
Anlagen.
In: Gesellschaft für Arbeitswissen e.V.
(Ed.):
Kompetenzentwicklung in realen und
virtuellen Arbeitssystemen.
Dortmund : GfA-Press, Dortmund, 2007,
pp. 101-104, ISBN 978-3-936804-04-1

Maasland, M. ; Teutsch, C.:
Kombinierte optische Vermessung und
Oberflächenprüfung von 3-D-Objekten.
In: Bauer, N. (Ed.):
Handbuch zur industriellen Bildverarbei-
tung – Qualitätssicherung in der Praxis.
Stuttgart : Fraunhofer IRB Verlag, 2007,
pp. 306-312, ISBN 978-3-8167-7386-3

Müller, H. ; Endig, M. ; Ryll, F.:
PMO-Services – Ganzheitliche Produkt-
service-Lösungen für den Maschinen-
und Anlagenbau.
In: 28. VDI/VDEh-Forum Instandhaltung
2007 – Instandhaltung auf dem
Prüfstand.
(Stuttgart, June 19 - 20, 2007) –
Proceedings, ISBN 978318091991

Müller, H. ; Hänsch, K. ; Endig, M. ; Ryll, F.:

Sicherung und Anwendung von Erfahrungswissen zur Unterstützung eines wirtschaftlichen und sicheren Betriebs technischer Systeme.

In: KnowTech 2007: Mehr Wissen – mehr Erfolg! – 9. Kongress zum IT-gestützten industriellen Wissensmanagement. (Frankfurt am Main, November 28 - 29, 2007) – Proceedings, ISBN 3-88260-077-2

Müller, G. ; Jungjohann, J.:

Workshop-Potentiale zustandsabhängiger Instandhaltung oder Wie wirtschaftlich ist die zustandsabhängige Instandhaltung wirklich?

In: VDI (Ed.): VDI/VDEh-Forum Instandhaltung 2007. (Stuttgart, June 18 - 20, 2007) – Proceedings

Müller, G. ; Plate, C.:

Anwendungsgebiete der RFID-Technologie in der Instandhaltung.

In: Brandow, G. ; Martin, W. (Eds.): RFID in der Instandhaltung. Dortmund : Verlag Praxiswissen, 2007 pp. 11-22, ISBN 978-3-89957-061-8

Müller, G. ; Richter, K. ; Plate, C. ; Mandelartz, J.:

Optimizing Maintenance Processes with RFID.

In: Italian National Committee for Maintenance (Ed.): Maintenance Management 2007 (Rome, Italy, September 27 - 28, 2007) – Proceedings, pp. 223-228, ISBN 978-88-95405-02-5

Nestorovic, T. ; Köppe H. ; Gabbert, U.:

A Direct Model Reference Adaptive Control System Design and Simulation for the Vibration Suppression of a Piezoelectric Smart Structure, in Nonlinear Science and Complexity.

In: Luo, A. ; Dai, L. ; H. Hamidzadeh (Eds.): Transactions of Nonlinear Science and Complexity, Volume 1. Singapore : World Scientific, 2007, pp. 375-381, ISBN 13 978-981-270-436-8, ISBN 10 981-270-436-1

Nestorovic, T. ; Köppe, H. ; Gabbert, U.: Direct Model Reference Adaptive Control (MRAC) Design and Simulation for the Vibration Suppression of Piezoelectric Smart Structures.

In: Communications in Nonlinear Science and Numerical Simulation. (2007), ISSN 1007-5704

Nestorovic, T. ; Lefèvre, J. ;

Ringwelski, S. ; Gabbert, U.: Finite Element and Subspace Identification Approaches to Model Development of a Smart Acoustic Box with Experimental Verification.

In: International Journal of Applied Mathematics and Computer Science: Advances in Computer, Electrical and Systems Science and Engineering. (2007) 2, pp. 817-822, ISSN 1305-5313

Nestorovic, T. ; Lefèvre, J. ; Gabbert, U.: Finite Element Model Based Controller Design for the Active Noise Control of the Acoustic Box.

In: IX Triennial International Conference on Systems, Automatic Control and Measurements. (Nis, Serbia, November 22 - 23, 2007) – Proceedings, pp. 175-178, ISBN 978-86-85195-49-5

Nestorovic, T. ; Lefèvre, J. ;

Ringwelski, S. ; Gabbert, U.: Model-based Active Noise Control of a Piezoelectric Structure.

In: 8th Conference on Active Noise and Vibration Control Methods. (Cracow-Krasiczyn, Poland, June 11 - 14, 2007) – Proceedings, pp. 259-269, ISBN 83-89772-41-8

Nestorovic, T. ; Lefèvre, J. ;

Ringwelski, S. ; Gabbert, U.: Model Reference Adaptive System for the Noise Control of an Active Piezoelectric Acoustic Box.

In: ASME (Ed.): ASME International Design Engineering Technical Conferences & Computers and Information in Engineering Conference, 21st Biennial Conference on Mechanical Vibration and Noise. (Las Vegas, USA, September 4 - 7, 2007) – Proceedings, pp. DETC2007-34565, ISBN 0-7918-3806-4

Richter, K. ; Gebert, B.:

Virtual Reality macht RFID sichtbar.

In: Klock, E. (Ed.): OEM & Lieferant Jahrbuch 2007. Stadelken-Elsheim : Elisabeth Klock, 2007, pp. 136-137, ISBN 978-3-00-02753-2

Ringwelski, S. ; Lefèvre, J. ;

Nestorovic, T ; Gabbert, U.: Active Noise Reduction of Vibroacoustic Systems Using Model Based Control.

In: Deutsche Gesellschaft für Akustik (DEGA) (Ed.): 33rd German Annual Conference on Acoustics 2007. (Stuttgart, March 19 - 22, 2007) – Proceedings, pp. 217-218, ISBN 978-3-9808659-3-7

- Röben, H.:
Bauteilmanagement.
In: Bandow, G. ; Martin, W. (Eds.):
RFID in der Instandhaltung.
Dortmund : RFID Praxiswissen, 2007,
pp. 103-114, ISBN 978-3-89957-061-8
- Ryll, F. ; Kutzler, T.:
Bestimmung von Abnutzungsvorräten in
technischen Anlagen zur Gestaltung
einer zustandsorientierten Instandhal-
tungsstrategie – Erfahrungsbasierte
Entscheidungsunterstützung.
In: Verein Deutscher Ingenieure (Ed.):
23. Tagung Technische Zuverlässigkeit
(Stuttgart, March 22 - 23, 2007) –
Proceedings, pp. 65-75,
ISBN 978-3-18-091984-3
- Schenk, M.:
Fraunhofer-Innovation in Sachsen-Anhalt
15 Jahre Forschung für die Praxis.
In: ARGOS das Wirtschaftsmagazin
für Mitteldeutschland.
(2007) 2, pp. 34-35, ISSN 0949-8648
- Schenk, M.:
Gesicherte Warenketten – Voraussetzung
für internationalen Kooperation.
In: Schenk, M. (Ed.):
Interlogistica Tagung "Logistische
Prozesse in den Bereichen Luftfahrt,
Automobil und Transportwesen: Qualität
und Sicherheit".
(Moscow, Russia, April 25 - 26, 2007) –
Proceedings
- Schenk, M.:
Nutzung virtueller Welten zur Qualifizie-
rung von Personal für die Handhabung
komplexer technischer Systeme.
In: Technologie- und Gründerzentrum
Jerichower Land (Ed.):
Innovationsforum Elektronenstrahltech-
nologie im Maschinen- und Apparatebau.
(Burg, March 7 - 8, 2007) – Proceedings
- Schenk, M.:
Smart, sicher und schnell: RFID und
Galileo leiten durch die Innenstadt.
In: Die Welt spezial: Fracht und Logistik,
24th BVL German Logistics Congress
(Berlin, October 17 - 19, 2007)
- Schenk, M.:
Virtuelle Techniken – eine regionale
Kompetenz und ein Dienstleistungs-
angebot für KMU.
In: MD-ECZ (Ed.):
virtuell entwickeln, testen und real
produzieren.
(Magdeburg, February 1, 2007) –
Proceedings, pp. 13-30
- Schenk, M. ; Barfus, K.:
Kausalanalytische Abbildung des logis-
tischen Prozesses mit Methoden der
Kybernetik und des vernetzten Denkens.
In: Engelhardt-Nowitzki, C. (Ed.):
Leobener Logistik Cases; Management
komplexer Materialflüsse mittels
Simulation.
Leoben : Deutscher Universitätsverlag,
2007, pp. 39-54,
ISBN 978-3-8350-0963-9
- Schenk, M. ; Bluemel, E.:
Lernplattformen zum Anlauf und Betrieb
von Produktionssystemen.
In: Industrie Management – Zeitschrift für
industrielle Geschäftsprozesse.
(2007) 3, pp. 23-26, ISSN 1434-1980
- Schenk, M. ; Hoyer, L.:
Technologieentwicklungen zur Nutzung
nachwachsender Rohstoffe und zur Ein-
führung dezentraler Energieversorgungs-
systeme.
In: Staatskanzlei Sachsen-Anhalt (Ed.):
14. Wittenberger Gespräche "Klimawan-
del und Ressourcenbegrenzung" –
Zukunft alternativer Energien.
(Lutherstadt Wittenberg, April 13 - 14,
2007) – Proceedings, pp. 83-99
- Schenk, M. ; Jenewein, K.:
Kompetenzentwicklung in virtuellen
Arbeitssystemen.
In: Gesellschaft für Arbeitswissenschaft
(GfA) (Ed.):
53. Kongress der Gesellschaft für Arbeits-
wissenschaft Kompetenzentwicklung in
realen und virtuellen Arbeitssystemen.
(Magdeburg, February 28 - March 1,
2007) – Proceedings, pp. 781-784,
ISBN 978-3-936804-04-1
- Schenk, M. ; Richter, K.:
Telematik und RFID – Elektronischer
Beobachter gestalten die gesicherte
Warenkette.
In: Bullinger, H.-J. ; Homel, M. (Eds.):
Internet der Dinge.
Heidelberg : Springer, 2007, pp. 77-89,
ISBN 978-3-540-36729-1
- Schenk, M. ; Richter, K. ; Müller, L.:
Mobile Business – MIDAS.
In: ARGOS – Das Wirtschaftsmagazin für
Mitteldeutschland.
15 (2007) 1, pp. 31-32, ISSN 09498648
- Schenk, M. ; Richter, K. ; Plate, C.:
Papierlos und effizient mit RFID die
Unternehmensprozesse unterstützen.
In: FVI (Ed.):
3. FVI-Jahresforum "RFID in der Instand-
haltung"
(Berlin, November 7 - 8, 2007) –
Proceedings
- Schenk, M. ; Ryll, F.:
Erfahrungsbasierte Entscheidungsunter-
stützung des Anlagenmanagements für
einen sicheren und wirtschaftlichen
Anlagenbetrieb.
In: 20. HAB Forschungsseminar der Hoch-
schulgruppe der Arbeits- und Betriebs-
organisation "Wettbewerbsfähigkeit
durch Arbeits- und Betriebsorganisation".
(Potsdam, October 12 - 13, 2007) –
Proceedings

- Schenk, M. ; Ryll, F. ; Endig, M.:
Dynamische Zustandsbewertung technischer Anlagen – Erfahrungs-basierte Entscheidungsunterstützung für das Anlagenmanagement.
In: wt Werkstattstechnik online.
Düsseldorf : Springer-VDI-Verlag GmbH 97 (2007) 7/8, pp. 572-578, ISBN 1436-4980
- Schenk, M. ; Tolujew, J. ; Barfus, K. ; Reggelin, T.:
Grundkonzepte zu logistischen Echtzeitsystemen: Monitoring, Event Management und Frühwarnung.
In: Hanne Wolf Kluthausen (Ed.):
Jahrbuch der Logistik 2007.
Korschenbroich : free beratung GmbH, 2007, pp. 222-226, ISBN 3-9809412-3-X
- Schenk, M. ; Tolujew, J. ; Reggelin, T.:
Dynamisches Betreiben von Produktionsnetzen.
In: Industrie Management.
(2007) 5, pp. 19-23, ISSN 1434-1980
- Schenk, M. ; Tolujew, J. ; Reggelin, T.:
Mesoskopische Modellierung und Simulation von Flusssystemen.
In: Logistic Collaboration ; Ivanov, D. ; Müller, E. ; Lukinsky, V. (Eds.):
2. Deutsch-Russischer Logistik Workshop. (Chemnitz, May 9 - 13, 2007) – Proceedings, pp. 40-49, ISBN 5-7422-1480-4
- Schmucker, U. ; Rusin, V. ; Konyev, M.:
Contact Processing in the Simulation of the Multi-body Systems.
In: 6th Eurosim Congress on Modelling and Simulation.
(Ljubljana, Slovenia, September 9 - 13, 2007) – Proceedings, pp. 76, ISBN 978-3-901608-32-2
- Schulenburg, E. ; Elkmann, N. ; Fritzsche, M. ; Girstl, A. ; Stiene, S. ; Teutsch, C.:
LiSA: A Robot Assistant for Life Sciences.
In: Hertzberg, J. ; Beetz, M. ; Englert, R. (Eds.):
30th Annual German Conference on AI (KI 2007).
(Osnabrück, September 10 - 13, 2007) – Proceedings
- Schulenburg, E. ; Elkmann, N. ; Fritzsche, M. ; Teutsch, C.:
A Mobile Service Robot for Life Science Laboratories.
In: Berns, K. ; Luksch, T. (Eds.):
20. Fachgespräch Autonome Mobile Systeme.
(Kaiserslautern, October 18 - 19, 2007) – Proceedings, ISBN 978-3-540-74763-5
- Seidel, H. ; Walter, R. ; Ryll, F.:
Gestaltungsoption Fabrik.
In: Schenk, M. (Ed.):
IFFOCUS: Logistik verbindet.
(2007) 1, pp. 3, ISSN 1862-5320
- Staiger, M. ; Gatzke, J.:
Wissensmanagement: Lernen Sie, Ihr individuelles Wissen optimal zu managen
In: Das Deutsche Ingenieur-Handbuch – Praxishandbuch für technische Führungskräfte
(2007) 3, pp. 63-80, ISSN 1613-2823
- Teutsch, C. ; Berndt, D. ; Trostmann, E. ; Preim, B.:
Adaptive Real-Time Grid Generation from 3D Line Scans for fast Visualization and Data Evaluation.
In: 11th International Conference Information Visualisation.
(Zurich, Switzerland, July 4 - 6, 2007) – Proceedings, pp. 177-184, ISBN 0-7695-2900-3
- Tissot, C. ; Strauchmann, M. ; Haase, T. ; Kissner, H. ; de Dios, M.:
Semantic Virtual Engineering Environment for Product Design.
In: Schenk, M. (Ed.):
10th IFF Science Days.
(Magdeburg, June 27, 2007) – Proceedings, pp. 39-46, ISBN-978-3-8167-7383-2
- Tümler, J. ; Mecke, R. ; Doil, F. ; George, P.:
Mobile Augmented Reality in industriellen Anwendungen: Nutzerzentrierte Fragestellungen und Ansätze für deren Lösung.
In: Böckelmann, I. ; Pfister, E. A. (Eds.):
11. Symposium Arbeitsphysiologie für Nachwuchswissenschaftler. – Proceedings, ISBN 978-3-00-022757-8
- Tümler, J. ; Mecke, R. ; Xu, J.:
See-Through Kalibrierverfahren für mobile Augmented Reality Assistenzsysteme.
In: Augmented und Virtual Reality in der Produktentstehung.
(2007), pp. 233-247, ISSN 978-3-939350-28-9
- Vajta, L. ; Urbancsek, T. ; Vajda, F. ; Juhasz, T.:
Comparison of Different 3-D (Stereo) Visualization Methods – Experimental Study.
In: 6th Eurosim Congress on Modelling and Simulation.
(Ljubljana, Slovenia, September 9 - 13, 2007) – Proceedings, pp. 351, ISBN 978-3-901608-32-2
- Voigt, S. ; Fischer, M. ; Staiger, M.:
Erfahrungen sichern – Projektwissen transferieren.
In: wissensmanagement – Das Magazin für Führungskräfte.
9 (2007) 2, ISSN 1438-4426

Presentations

(Selection)

Voigt, S. ; Staiger, M. ; Finke, I. ;
Orth, R.:
ProWis – Eine prozessorientierte Heran-
gehensweise zum Wissensmanagement
in KMU.

In: Gronau, N. (Ed.):
4. Konferenz Professionelles Wissens-
management – Erfahrungen und Visionen
(Potsdam, March 28 - 30, 2007) –
Proceedings, pp. 51-59,
ISBN 978-3-936771-98-5

Walter, C. ; Schulenburg, E. ; Beier, D. ;
Elkmann, N.:

Data Acquisition and Processing Using
a Service Oriented Architecture for an
Automated Inspection System.

In: IEEE Fourth International Workshop
on Data Acquisition and Advanced
Computing Systems.
(Dortmund, September 6 - 8, 2007) –
Proceedings, ISBN 1-4244-1348-6

Walter, C. ; Schulenburg, E. ; Beier, D. ;
Elkmann, N.:

Handling the Time Delay of Sensor Data
Processing in a Model Based Remote
Operation Environment.

In: Schilling, K. (Ed.):
13th IASTED International Conference on
Robotics and Applications.
(Würzburg, August 28 - 31, 2007) –
Proceedings, ISBN 978-0-88986-685-0

Blümel, E.:
Virtuelle Qualifizierung in der Industrie :
Presentation.

At: BITKOM Innovationsforum auf der
Systems 2007
(Munich, October 26, 2007)

Endig, M.:
Content Services als Basis moderner
Produktservicestrategien für den
Maschinen- und Anlagenbau :
Presentation.

At: Anwenderforum Teleservice
(Frankfurt am Main, March 15, 2007)

Endig, M.:
Einsatz virtueller Technologien für
Produktentstehung und Betrieb am
Beispiel eines Biomassekraftwerks :
Presentation.

At: 2. Fachgespräch Kraftwerke
(Magdeburg, September 13 - 14, 2007)

Endig, M.:
Lebenszyklusübergreifende Dokumen-
tation als Grundlage für einen sicheren
Anlagenbetrieb : Presentation.
At: 17. Fachgespräch Anlagensicherheit
der TÜV Rheinland Group
(Cologne, August 30, 2007)

Endig, M.:
Plant Maintenance and Operation
Services oder was kostet es Sie, wenn
Ihre Anlage eine Stunde still steht :
Presentation.
At: 1. PC-Soft Anwenderfachtagung
(Grossräschen, September 6 - 7, 2007)

Herrmann, A.:
Untersuchungen zur optimalen
Reformierung von Erd- und Biogas :
Presentation.
At: 4th IFF Colloquium
(Magdeburg, September 28, 2007)

Komarnicki, P. ; Müller, G. ; Dzienis, C. ;
Styczynski, Z. A. ; Gollub, I. ;
Blumschein, J.:

PMU Placement Method Based on
Decoupled Newton Power Flow and
Sensitivity Analysis : Presentation.
At: 9th International Conference on
Electrical Power Quality and Utilization –
EPQU 2007
(Barcelona, Spain, October 9 - 11, 2007)

Komarnicki, P. ; Müller, G. ; Dzienis, C. ;
Styczynski, Z. A. ; Phadke, A. ;
Blumschein, J.:

Optimized Testing Procedures for Phasor
Measurement Units : Presentation.
At: 13th International Scientific
Conference: Present-Day Problems of
Power Engineering – APE'07
(Jurata, Poland, June 13 - 15, 2007)

Kroitzsch, J.:
Herausforderung Elektroauto :
Presentation.

At: Forum Antriebssysteme
(Wernigerode, June 27, 2007)

Kutzler, T. ; Ehrhardt, I. ; Wäsche, M.:
Telematiktechnologien und -dienste für
die integrierte Logistik bei Behörden und
Organisationen mit Sicherheitsaufgaben
(BOS) : Presentation.

At: POSITIONS 2007 – Kongress für
Nutzer und sicherheitskritische Anwen-
dungen Satelliten gestützter Ortung im
deutschsprachigen Raum
(Braunschweig, October 16, 2007)

Richter, K.:
Die Ware funkt – Technologien für die
gesicherte Warenkette : Presentation.

At: CeBit in Motion – Forum for
Telematics & Navigation
(Hannover, March 19, 2007)

- Richter, K.:
ICT als wichtige Voraussetzung für Innovation, Wachstum, Internationalisierung und Beschäftigung : Presentation.
At: Erstes Europäisches CeBIT-Expertenforum für Innovation und Internationalisierung im Mittelstand 2007 (Hannover, March 16, 2007)
- Ryll, F.:
Methoden und Werkzeuge zur Gestaltung einer zustandsorientierten Instandhaltungsstrategie : Presentation.
At: Fachgespräch Anlagensicherheit (Bad Dürkheim, May 23, 2007)
- Ryll, F.:
Methoden und Werkzeuge zur Gestaltung einer zustandsorientierten Instandhaltungsstrategie, Arbeitstreffen – Statelogger Workshop : Presentation.
At: 10th Science Days (Magdeburg, June 28, 2007)
- Schenk, M.:
3-D-Projektionen: Potenziale neuer Technologien in Stadtplanung und Architektur : Presentation.
At: Landesfachkommission Bau (Magdeburg, June 19, 2007)
- Schenk, M.:
Das Fraunhofer IFF – Forschung für die Praxis : Presentation.
At: Beiratssitzung der Bundesvereinigung Logistik (Magdeburg, May 10, 2007)
- Schenk, M.:
Die Technologieplattform MIDAS : Presentation.
At: Mitteldeutscher Abend zum Thema "Logistik in Mitteldeutschland" (Berlin, March 7, 2007)
- Schenk, M.:
Die Technologieplattform MIDAS : Presentation.
At: 8. Deutsch-Russisches Symposium "Verkehrswirtschaft" (Leipzig, June 12, 2007)
- Schenk, M.:
Einsatz virtueller Technologien für die tägliche Arbeit : Presentation.
At: 10. Erfahrungsaustausch der Sicherheits- und Gesundheitsschutzkoordinatoren (Magdeburg, November 28, 2007)
- Schenk, M.:
Forschung für die Praxis : Presentation.
At: Gemeinsamer Workshop des Bundesverbandes mittelständische Wirtschaft (BVMW), des Fraunhofer IFF und des Netzwerkprojekts NETWORK-KMU Technische Innovationen für mittelständische Unternehmen (Magdeburg, March 15, 2007)
- Schenk, M.:
Forschung für die Praxis : Presentation.
At: Werner-von-Siemens-Gymnasium's visit to the VDTC (Magdeburg, October 22, 2007)
- Schenk, M.:
Forschung für die Praxis : Presentation.
At: Industrieclub Magdeburg e.V. (Magdeburg, July 19, 2007)
- Schenk, M.:
Funktechnologien erobern das logistische Objekt : Presentation.
At: Workshop RFID-gestützte Baustellenlogistik: Einsatz von RFID im grosstechnischen Anlagenbau (Magdeburg, February 21, 2007)
- Schenk, M.:
Ingenieure sind gefragt und sichern Zukunft! : Presentation.
At: Saxony-Anhalt VDI 2007 New Year's Reception (Magdeburg, January 17, 2007)
- Schenk, M.:
Ingenieure sind gefragt und sichern Zukunft : Presentation.
At: VDI Member Meeting 2007 (Halle, April 21, 2007)
- Schenk, M.:
Interlogistica als eine Plattform der deutsch-russischen Zusammenarbeit : Presentation.
At: 2. Deutsch-Russischer Logistik Workshop (Chemnitz, May 10, 2007)
- Schenk, M.:
Logistikforschung am Standort Magdeburg – ILM und IFF : Presentation.
At: Interlogistica (Moscow, Russia, April 24, 2007)
- Schenk, M.:
Roboter in der Fassadenreinigung – die Zukunft des Fensterputzens : Presentation.
At: Lecture Series "Wissenschaft populär" (Magdeburg, October 25, 2007)
- Schenk, M.:
Trends im Automobilbau – Lösungsansätze für die Zulieferindustrie : Presentation.
At: Forum "Optische Technologien und Kunststoffanwendungen im Automobil" (Jena, March 21, 2007)
- Schenk, M.:
Unternehmerperspektiven – Innovationen als Erfolgsfaktor im Mittelstand : Presentation.
At: Innovationstag der Commerzbank (Magdeburg, July 10, 2007)
- Schenk, M.:
Virtuell interaktives Training – Mensch und Maschine im interaktiven Dialog Innovative Qualifizierungsangebote für global agierende Unternehmen : Presentation.
At: Advisory Board Meeting of the German Logistics Association (Magdeburg, May 11, 2007)

- Schenk, M.:
Virtuelle Arbeitssysteme – zukünftige Entwicklungstrends bei der Mensch-Maschine-Interaktion : Presentation.
At: GFE e.V. 15th Anniversary Event (Schmalkalden, June 20, 2007)
- Schenk, M.:
Virtuelle Techniken – eine regionale Kompetenz und ein Dienstleistungsangebot für KMU : Presentation.
At: 50. AVW-Podium für Management und Personalfragen (Magdeburg, February 20, 2007)
- Schenk, M.:
Virtuelle Technologien – regionale Kompetenz und Dienstleistungsangebot für KMU : Presentation.
At: innoLOGIST 2007 (Leipzig, September 25, 2007)
- Schenk, M.:
Wissen um das Wissen : Presentation.
At: Commerzbank Magdeburg New Year's Reception (Magdeburg, January 10, 2007)
- Schenk, M. ; Höpfner, A.:
Das VDTK – Tor zur virtuellen Welt : Presentation.
At: IBA Stadtumbau 2010 Magdeburg Leben an und mit der Elbe, II IBA Conference "Netzwerk Elbe" (Magdeburg, December 3, 2007)
- Schenk, M. ; Richter, K.:
Sicherheit bei kleinvolumigen Wirtschaftsverkehren : Presentation.
At: Positions 2007 (Braunschweig, October 16, 2007)
- Schenk, M. ; Seidel, H.:
Prozessoptimierung und Wertstromanalyse durch Informationstransparenz und durchgängige Informationsverfolgung - Neue Methoden und Technologien : Presentation.
At: Jenoptik Advisory Board Meeting (Jena, June 12, 2007)
- Schotte, E.:
Energetic Utilization of Biomass in Distributed Applications : Presentation.
At: Forum of Interregional Cooperation on Biomass Utilization (Nyíregyháza, Hungary, September 20 - 21, 2007)
- Schotte, E. ; Lemin, B.:
Sauerstoff-Festelektrolyt-Sonden (GSFS): Einsatz in thermo-chemischen Prozessen : Presentation.
At: European Summer School on Analysis and Treatment of Gases and Solids in Thermo-chemical Conversion of Biomass (Jülich, August 27 - 31, 2007)
- Schotte, E. ; Lemin, B.:
Verfahrensentwicklung zur Regelung und Prozesskontrolle von Brenngasreinigungsapparaturen mittels gaspotentiometrischer Sauerstoff-Festelektrolyt-Sensoren (GSFS) : Presentation.
At: Final ReGasNet Project Meeting (Oberhausen, July 4, 2007)
- Strauchmann, M. ; Haase, T. ; Jamin, E. ; Cherfi, H. ; Renteria, M. ; Tissot, C.:
Coaction of Semantic Technology and Virtual Reality in an Integrated Engineering Environment : Presentation.
At: Workshop on Knowledge Management and Semantic Web for Engineering with the Fourth International Conference on Knowledge Capture (Whistler, Canada, October 28, 2007)
- Thomas, S.:
Energetische Nutzung von Biomasse in dezentralen Anlagen : Presentation.
At: Fachgespräch Kraftwerke (Magdeburg, September 14, 2007)
- Thomas, S.:
Entwicklung eines Prototypen zur Produktion von Biowasserstoff für Brennstoffzellen aus Biomethan : Presentation.
At: Workshop NEMO Netzwerk INNOGAS (Dessau, May 10, 2007)
- Thomas, S.:
Integrierte Prozesssysteme zur energetischen Nutzung von Biomasse in Brennstoffzellen (ProBio) : Presentation.
At: 4th IFF Colloquium (Magdeburg, April 20, 2007)
- Thomas, S. ; Schotte, E.:
Erzeugung und Aufbereitung biogener Gase zur energetischen Nutzung in Brennstoffzellen : Presentation.
At: VDI-Arbeitskreistreffen Chemieingenieurwesen und Verfahrenstechnik (Magdeburg, February 14, 2007)
- Thomas, S. ; Seidel-Morgenstern, A.:
Production of H-rich Gases for Fuel Cells Using Membranes : Presentation.
At: Workshop, EU-Projekt COST 543 (Freising, January 31 - February 1, 2007)
- Voigt, S.:
Projekterfahrungen sinnvoll nutzen – Das Rad nicht neu erfinden : Presentation.
At: Meeting of Heads of Departments 2007 (Munich, October 17, 2007)
- Voigt, S.:
Wissen managen – Projekterfahrungen sichern : Presentation.
At: GPM Regional Chapter Meeting (Magdeburg, August 29, 2007)
- Voigt, S.; Staiger, M.:
Wissensmanagement Praxis – Wissensmanagement mit Methode : Presentation.
At: Block Seminar "Wissensmanagement Praxis – Wissensmanagement mit Methode" (Magdeburg, May 11, 2007)

Fraunhofer



Photo: Berndt Liebl

The Research Organization



The Fraunhofer-Gesellschaft's primary task is applied research. Founded in 1949, the research organization performs applied research for business and industry and to the benefit of society. Contractual partners and clients include industrial and service companies and the state. On behalf of federal and state ministries and agencies, it carries out research projects relevant for the future, which contribute to innovations in the public and private sectors.

The impact of applied research reaches far beyond its direct benefits for clients: Fraunhofer Institutes contribute to regional, German and European competitiveness with their research and development work. They foster innovations, encourage technological advances, improve acceptance of modern technology and also provide young researchers and engineers much needed information and advanced training.

The Fraunhofer-Gesellschaft provides its staff opportunities to develop professionally and personally for challenging positions at their institutes, other fields of research, business and society. The practical training and experience at Fraunhofer Institutes open outstanding opportunities for students to find jobs and develop at organizations and companies.

The Fraunhofer-Gesellschaft currently operates over eighty research facilities, of which fifty-six are institutes, at forty locations all over Germany. 12,500 employees, predominantly with backgrounds in the natural sciences or engineering, work with an annual research budget of 1.2 billion euros. Of this, over 1 billion euros is generated by contract research. The Fraunhofer-Gesellschaft obtains two thirds from industry contracts and publicly funded research projects. Only one third is contributed by federal and state governments as basic funding so that the institutes can work to solve problems that will only become relevant for business and society in ten or fifteen years.

Research centers and representative offices in Europe, the USA and Asia maintain contact with the most important present and future research and business regions.

The namesake of the non-profit Fraunhofer-Gesellschaft is the brilliant Munich native Joseph von Fraunhofer (1787-1826) who enjoyed equal success as a researcher, inventor and entrepreneur.

Fraunhofer IFF Contacts at a Glance



Photo: Andreas Lander

Kontakt

Director	Prof. Michael Schenk Tel. +49 (0) 391/40 90-470	Michael.Schenk@iff.fraunhofer.de Telefax +49 (0) 391/40 90 93-470
Office of the Director Office Manager	Ines Trübe Tel. +49 (0) 391/40 90-471	Ines.Truebe@iff.fraunhofer.de Telefax +49 (0) 391/40 90 93-471

Deputy Director	Dr. Gerhard Müller Tel. +49 (0) 391/40 90-401	Gerhard.Mueller@iff.fraunhofer.de Telefax +49 (0) 391/40 90 93-401
Office	Sabine Gerlich Tel. +49 (0) 391/40 90-444	Sabine.Gerlich@iff.fraunhofer.de Telefax +49 (0) 391/40 90 93-444

Organization and Communication Team OKT

Organisation and Communication	Sabine Conert Tel. +49 (0) 391/40 90-481	Sabine.Conert@iff.fraunhofer.de Telefax +49 (0) 391/40 90 93-481
Media and Public Relations	Anna-Kristina Wassilew Tel. +49 (0) 391/40 90-446	presse-vgtc@iff.fraunhofer.de Telefax +49 (0) 391/40 90 93-446
Organization and Coordination VDTC	Antje Plock Tel. +49 (0) 391/40 90-140	Antje.Plock@iff.fraunhofer.de Telefax +49 (0) 391/40 90 93-140

Business Units

Robotic Systems RS	Dr. Norbert Elkmann Tel. +49 (0) 391/40 90-222	Norbert.Elkmann@iff.fraunhofer.de Telefax +49 (0) 391/40 90 93-222
Measurement and Testing Technology MPT	Dirk Berndt Tel. +49 (0) 391/40 90-224	Dirk.Berndt@iff.fraunhofer.de Telefax +49 (0) 391/40 90 93-224
Virtual Interactive Training VIT	Dr. Eberhard Blümel Tel. +49 (0) 391/40 90-110	Eberhard.Bluemel@iff.fraunhofer.de Telefax +49 (0) 391/40 90 93-110
Logistics and Factory Systems LFS	Holger Seidel Tel. +49 (0) 391/40 90-123	Holger.Seidel@iff.fraunhofer.de Telefax +49 (0) 391/40 90 93-123
Process and Plant Engineering PAT	Dr. Matthias Gohla Tel. +49 (0) 391/40 90-361	Matthias.Gohla@iff.fraunhofer.de Telefax +49 (0) 391/40 90 93-361

Expert Groups

Virtual Engineering VE	Prof. Ulrich Schmucker Tel. +49 (0) 391/40 90-201	Ulrich.Schmucker@iff.fraunhofer.de Telefax +49 (0) 391/40 90 93-201
Material Handling Engineering and Systems MFT	Dr. Klaus Richter Tel. +49 (0) 391/40 90-420	Klaus.Richter@iff.fraunhofer.de Telefax +49 (0) 391/40 90 93-420
Virtual Prototyping VP	Dr. Rüdiger Mecke Tel. +49 (0) 391/40 90-146	Rüdiger.Mecke@iff.fraunhofer.de Telefax +49 (0) 391/40 90 93-146

Central Office

ViVERA	Marco Schumann Tel. +49 (0) 391/40 90-158	Marco.Schumann@iff.fraunhofer.de Telefax +49 (0) 391/40 90 93-158
--------	--	--

Administrative Services	Karla Zorn Tel. +49 (0) 391/40 90-598	Karla.Zorn@iff.fraunhofer.de Telefax +49 (0) 391/40 90 93-598
-------------------------	--	--

Institute of Logistics and Material Handling Systems, Otto von Guericke University Magdeburg

Managing Director	Prof. Michael Schenk Tel. +49 (0) 391/67-18 601	michael.schenk@mb.uni-magdeburg.de Telefax +49 (0) 391/67-12 646
Logistics Process Analysis	Dr. Elke Glistau Tel. +49 (0) 391/67-12 660	elke.glistau@mb.uni-magdeburg.de Telefax +49 (0) 391/67-12 646
Logistics Process Modeling	Dr. Juri Tolujew Tel. +49 (0) 391/40 90-310	Juri.Tolujew@iff.fraunhofer.de Telefax +49 (0) 391/40 90 93-310

Fraunhofer IFF Joint Competence Centers with Otto von Guericke University Magdeburg

Visualization Techniques	Prof. Bernhard Preim Tel. +49 (0) 391/67-18 512	bernhard@isg.cs.uni-magdeburg.de Telefax +49 (0) 391/67-11 164
Training and Technology	Prof. Klaus Jenewein Tel. +49 (0) 391/67-16 602	klaus.jenewein@gse-w.uni-magdeburg.de Telefax +49 (0) 391/67-16 550
Virtual Engineering	Prof. Ulrich Gabbert Tel. +49 (0) 391/67-18 609	ulrich.gabbert@mb.uni-magdeburg.de Telefax +49 (0) 391/67-12 439
	Prof. Roland Kasper Tel. +49 (0) 391/67-18 607	roland.kasper@mb.uni-magdeburg.de Telefax +49 (0) 391/67-12 656
Simulation Techniques	Prof. Thomas Schulze Tel. +49 (0) 391/67-12 825	schulze@iti.cs.uni-magdeburg.de Telefax +49 (0) 391/67-11 216
Machine Vision	Prof. Bernd Michaelis Tel. +49 (0) 391/67-18 860	bernd.michaelis@e-technik.uni-magdeburg.de Telefax +49 (0) 391/67-11 231
Power Systems and Renewable Energies	Prof. Zbigniew A. Styczyński Tel. +49 (0) 391/67-18 866	sty@e-technik.uni-magdeburg.de Telefax +49 (0) 391/67-12 408
Robotics and Embedded Systems	Prof. Jörg Kaiser Tel. +49 (0) 391/67-18 829	Kaiser@ivs.cs.uni-magdeburg.de Telefax +49 (0) 391/67-11 829

Editorial Notes

**Achievements and Results
Annual Report 2007
of the Fraunhofer Institute for
Factory Operation and Automation IFF**

Published by
Fraunhofer Institute for
Factory Operation and Automation IFF

Prof. Michael Schenk
Directorr

Sandtorstrasse 22
39106 Magdeburg
Germany
Tel. +49 (0) 391/40 90-0
Fax +49 (0) 391/40 90-596
ideen@iff.fraunhofer.de
www.iff.fraunhofer.de
www.vdnc.de

Edited by
Anna-Kristina Wassilew
Press and Public Relations
Fraunhofer Institute for
Factory Operation and Automation IFF

Translated by
Krister G. E. Johnson
English Services
Fraunhofer Institute for
Factory Operation and Automation IFF

Photos, images and graphics
© Fraunhofer IFF
unless credited otherwise.

Title photos
Photo 1 and 5: Dirk Mahler
Photo 3: Woody Stein
Photo 4: Anna-Kristina Wassilew

Copy editing/layout/design
Barbara Schmidt
Ingenieurbüro Schmidt

We thank our project partners and the employees of the Fraunhofer IFF for the release of their publications.

This material may only be reproduced with prior consent of the editorial staff.

© Fraunhofer IFF, Magdeburg 2008

